

1. This Guideline:

- Assists in keeping Stramit customers, visitors, employees and the general public safe from injury on Stramit sites, customer premises and on public roads
- Provides information on the state regulations and site requirements for transport of products from Stramit sites.
- Sets out minimum safety and load restraint requirements.

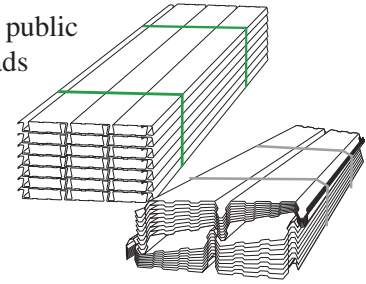

2. Site Requirements

- Where it is deemed necessary, Stramit may require you to wear PPE while you are on site. Equipment will be made available to you while on site, and must be returned before leaving the site.
- Customers must stay with their vehicle or in designated safe areas at all times and take direction from loading staff.
- Stramit personnel have final say.** It is unacceptable that a person be injured or property damaged as a result of vehicles being overloaded, loads overhanging inappropriately or loads restrained inappropriately.
- Loading exclusion zones must be adhered to at all times (see Section 7 Exclusion Zones).
- Customers must observe all site speed limits, traffic signs and staff directions.
- Alternative arrangements for delivery will be made if the vehicle or equipment is inappropriate for the load. (Charges Applicable)

3. Legislative Requirements

Adherence to this guideline assists Stramit and customers in meeting the following legislative requirements:

- OHS Acts & Regulations in accordance with the respective Australian State and Territory Legislation
- Guidelines & Performance Standards - National Transport Commission (NTC) Load Restraint Guide
- Chain of Responsibility
- ➔ **Any party who has control in a transport operation can be held responsible and may be made legally liable.**
- ➔ Liability for an offence will apply if a person knowingly, or ought have known, that their actions breaches a road transport law and/or is unsafe e.g. inadequate load restraint.
- ➔ For more information refer to the National Transport Commission web site at www.ntc.gov.au or contact the Transport Agency in your state.

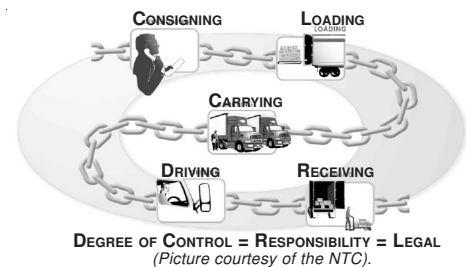

4. Weight & Load Requirements

- Carrying of long and/or heavy loads in a vehicle not designed for such purposes can be dangerous and in breach of the law. **Vehicles considered inappropriate will not be loaded.**
- Vehicles are not to be overloaded. This includes roof racks.
- Stramit will not load above the following limits without written verification that both the roof rack and the vehicle roof is capable of a higher load (including the load already on the vehicle):
 - ➔ **Car/Sports racks 40kg**
 - ➔ **Trades racks 100kg**
- Written verification of acceptable higher weights includes - the load rated sticker on the roof racks, information in the vehicle handbook, paperwork received with the roof racks, information from the suppliers website, engineering certificate.
- Vehicle stability (due to higher centre of mass) must also be considered. Check the vehicle handbook for more details.

5. Overhang Requirements

✓ The overhang limits on this page are for **ALL** vehicle types and are based on maximum limits for product protection and/or the state or territory regulations. Wide loads should not be inclined (due to wind loadings).

✗ **The drivers vision must not be obstructed.** Projections/overhangs that are dangerous are not acceptable, **even if they are within the limits below.**

✓ For daytime travel, a minimum 450 mm square bright red flag is required on any overhang that cannot be easily seen. This is mandatory for overhangs beyond 1200 mm past the end of a vehicle (e.g. for trucks).

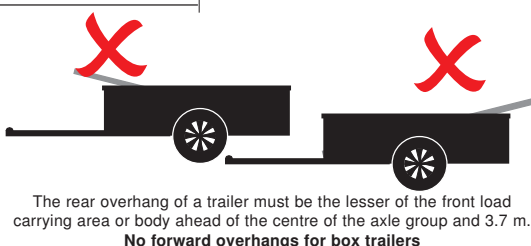
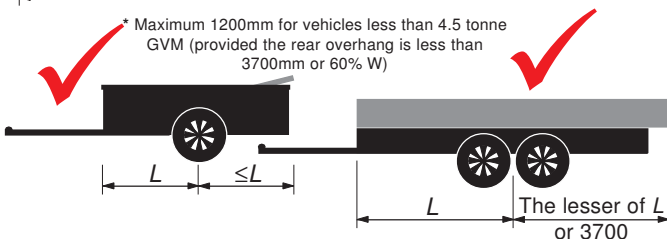
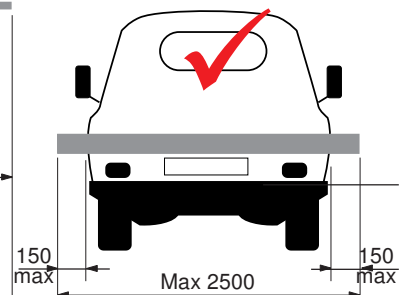
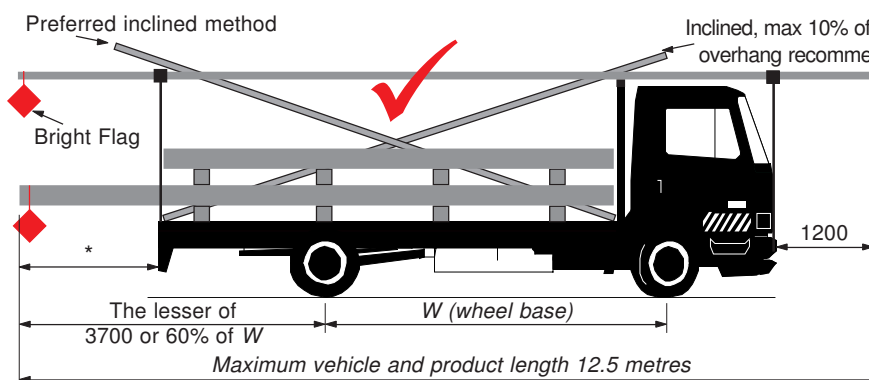
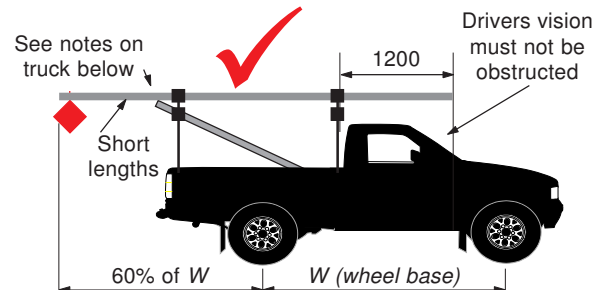
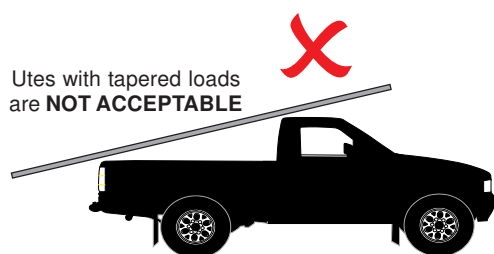
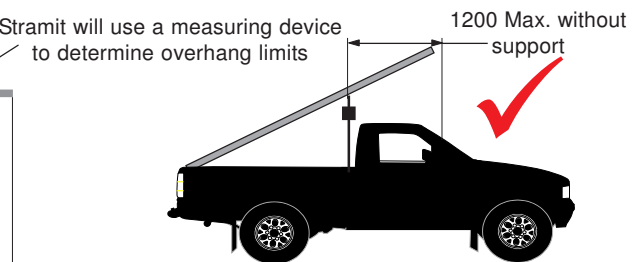
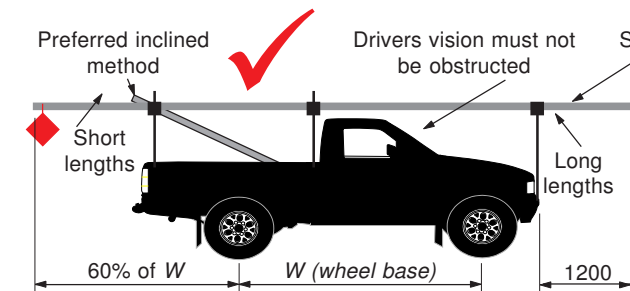
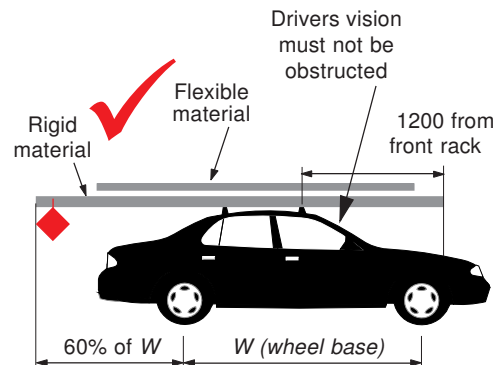

6. Load Restraint Requirements

- ➔ **Loads must be restrained to prevent unacceptable movement during all expected conditions of operation.** In particular the load must be restrained to be able to resist specific forces in different directions of movement. Please refer to the “Load Restraint Guide”, National Transport Commission: (<http://www.ntc.gov.au/ViewPage.aspx?page=A02208419300620020>).
- ➔ The following minimum load restraint requirements have been designed to meet the above conditions for securely strapped flat loads. Round loads must be belly wrapped and may require extra lashings.
- ➔ Recommended minimum 1 lashing per 1.5 metres along load for long or lightweight packs e.g. roofing.
- ➔ Packs will be required to be restrained as per **Table 1** or under the direction of Stramit Personnel.
- ➔ The load restraint equipment must be suitable for the nature of the product and meet the requirements set out in table 1. **Stramit personnel have the right to refuse to load** if they are not satisfied with the integrity of the load restraint equipment.

Do Not Use Occy Straps or Flexi Straps .

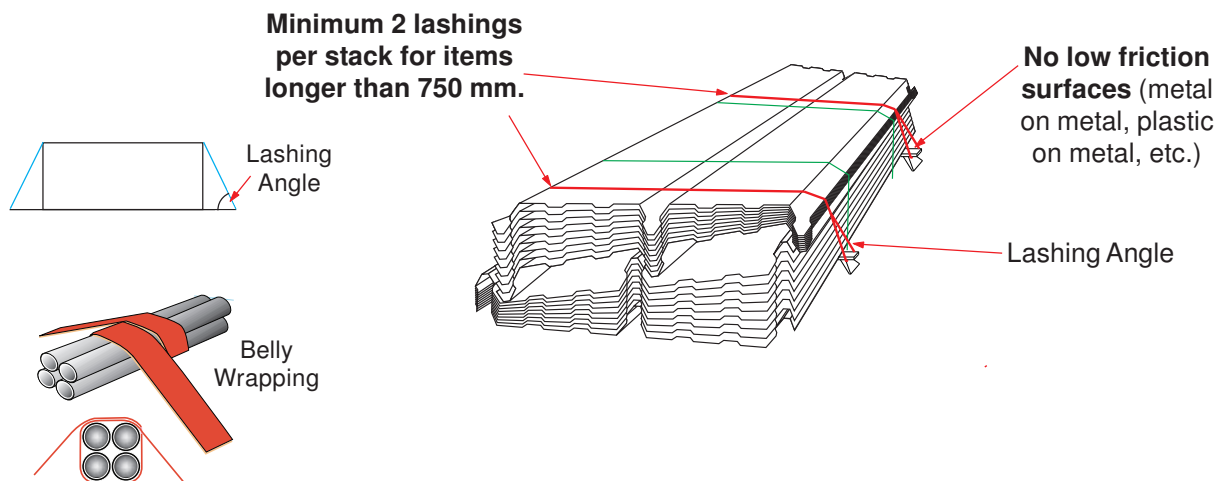

Table 1 - Lashing Requirements

| Lashing Angle to Horizontal \angle | 25 mm hand tightened webbing | 25 mm ratchet webbing | 35 mm ratchet webbing | 8 mm synthetic rope with single hitch |
|--------------------------------------|------------------------------|-----------------------|-----------------------|---------------------------------------|
| 60 to 90° | 52 kg per strap | 170 kg | 430 kg | 87 kg per rope |
| 45 to 60° | 46 kg per strap | 140 kg | 350 kg | 71 kg per rope |
| 30 to 45° | 30 kg per strap | 100 kg | 250 kg | 50 kg per rope |
| 15 to 30° | 15 kg per strap | 52 kg | 130 kg | 26 kg per rope |

Key Assumptions in Tables 1

1. All lashings are fully tensioned. If not, then more lashings may be required.
2. **No low friction surfaces** (e.g. steel on steel, plastic on plastic, plastic on steel, etc.)
3. A minimum static coefficient of friction of $\mu = 0.40$ is achieved under all products and between layers of a load. (e.g. rubber or timber against steel or plastic).
4. **Round loads** require **belly wrapping** and extra restraints.

7. Loading Exclusion Zones

- ➔ Customers must **stay in the designated safe area** whilst being loaded. They must not enter the danger exclusion zone until loading activities have ceased and loading staff have given the all clear to enter.
- ➔ The whole vehicle is an exclusion zone during loading of customer vehicles. Customers must stay more than 2 m from all moving loads and the vehicle being loaded.
- ➔ Customers should discuss with loading staff product placement prior to loading beginning.
- ➔ **Stay in the designated area and make sure the loader knows where you are at all times.**

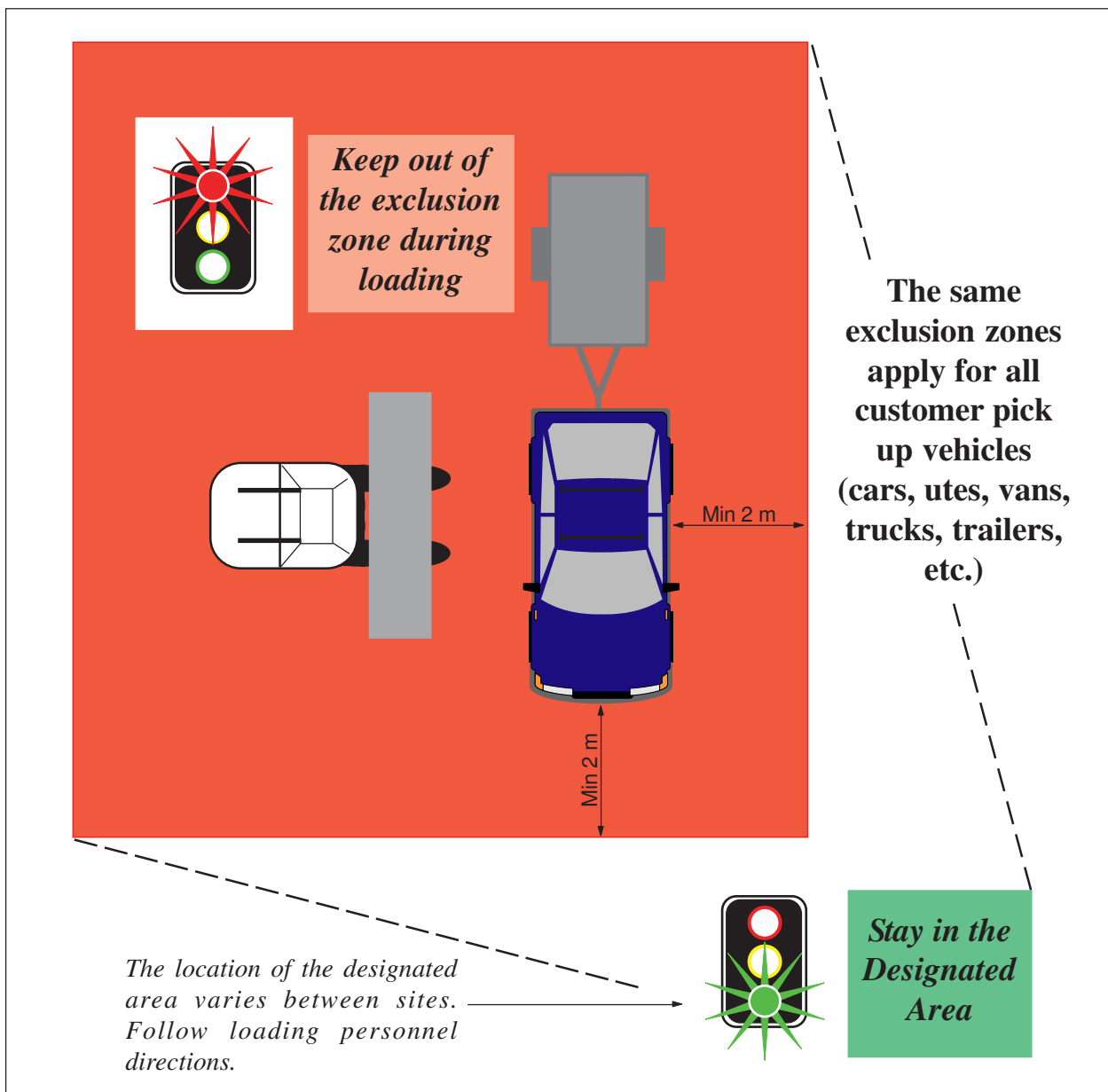

"These guidelines are provided to you by BlueScope Steel and Stramit for guidance only, and compliance with applicable laws and standards remains your responsibility. Whilst Stramit, in cooperation with BlueScope Steel and transport operators, has taken considerable care to develop transport safety guidelines that are effective and comply with all requirements, BlueScope Steel and Stramit makes no warranty as to the applicability of these methods in all circumstances. It remains your responsibility at all times to ensure that the methods you use are adequate for the particular situation and where appropriate you should take further precautions. The contents of these guidelines are confidential to and the property of BlueScope Steel, and you may only use these guidelines with permission from BlueScope Steel and Stramit."