

VENTILATION IN STEEL ROOFING

**Approaches to satisfy NCC2022
Condensation Management requirements for
residential roofs in Climate Zones 6, 7 and 8**

VSR V23 - INDUSTRY 23



AUSTRALIAN STEEL INSTITUTE

CONTENTS

DOCUMENT PURPOSE	2
NCC REQUIREMENTS FOR CONDENSATION MANAGEMENT IN ROOFS	3-4
APPLYING THE ROOF SPACE VENTILATION REQUIREMENTS	4-8
VENTILATION OPTIONS TO ACHIEVE COMPLIANCE	8-9
GUIDANCE ON VENTILATION PATHWAY OPTIONS	10
VENTILATION APPROACHES DRAWINGS	11-14
DEFINITIONS	14
NASH, ASI & CONTACTS	15

DOCUMENT PURPOSE

The purpose of this document is to provide guidance for building practitioners on approaches for steel roof systems to address new NCC ventilation of roof space requirements as set out in Australian Building Code Board (ABCB) Housing Provision Standard.

- Outlines the NCC2022 Deemed-to-Satisfy (DtS) requirements for roof ventilation.
- Explains how profiled steel roof claddings provide passive ventilation openings.
- Discusses approaches to incorporate ventilation into steel roofing systems.
- Provides examples of construction approaches, and drawings.

Condensation management is an ongoing focus area of building design and performance. Designers and construction professionals should also refer to the “Condensation Management for Steel Roofing - Principles and approaches for managing moisture in Australian residential steel roof systems” in this series.



AUSTRALIAN STEEL INSTITUTE

NCC REQUIREMENTS FOR CONDENSATION MANAGEMENT IN ROOFS

Condensation in buildings is the result of complex interactions between external environmental conditions, internal water vapour generation from occupant behaviour, and building construction. As buildings become more energy efficient through increasing insulation and air tightness, this is resulting in roof spaces becoming colder and the escape of water vapour from the building is slowed down. These changes can increase the likelihood of problematic condensation and moisture accumulation.

NCC 2022 Volume Two for houses requires that building elements exposed to water vapour and condensation, such as roofs and walls, be constructed to minimise the impact on the health of the occupants*. If not appropriately managed, the long term effects of water vapour and condensation can cause material degradation e.g. rot and give rise to unhealthy levels of mould.

Condensation risk in buildings is climate dependant and Condensation Management provisions vary dependant on the ABCB climate zone.

The ABCB Housing Provisions Standard Part 10.8.3 describes new Deemed-to-Satisfy (DtS) requirements for condensation management of roof spaces in the cooler climate zones 6, 7 and 8.

Roofs require an airspace between the primary insulation layer and the roof system that can be ventilated to allow escape of water vapour and drying of the building elements if wetting occurs.

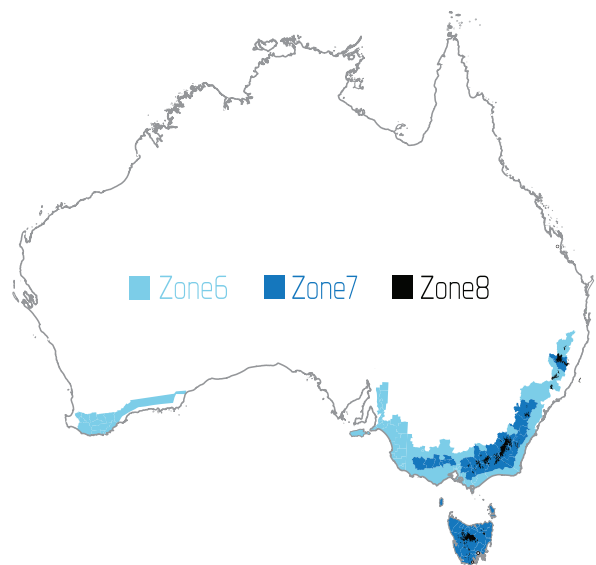

*NCC 2022 Vol 2 H407 objective

10.8.3 Ventilation of roof spaces

- (1) In climate zones 6, 7 and 8, a roof must have a roof space that—
 - (a) is located—
 - (i) immediately above the primary insulation layer; or
 - (ii) immediately above sarking with a vapour permeance of not less than 1.14 pg/N.s, which is immediately above the primary insulation layer; or
 - (iii) immediately above ceiling insulation that meets the requirements of 13.2.3(3) and 13.2.3(4); and
 - (b) has a height of not less than 20 mm; and
 - (c) is either—
 - (i) ventilated to outdoor air through evenly distributed openings in accordance with Table 10.8.3; or
 - (ii) located immediately underneath the roof tiles of an unsarked tiled roof.
- (2) The requirements of (1) do not apply to a—
 - (a) concrete roof; or
 - (b) roof that is made of structural insulated panels; or
 - (c) roof that is subject to Bushfire Attack Level FZ requirements in accordance with AS 3959.

VENTILATION OPENING REQUIREMENTS

In climate zones 6, 7 and 8, a roof must have a roof space that is ventilated to outdoor air through evenly distributed openings in accordance with Table 10.8.3 of the ABCB Housing Provisions Standard.

The intent of the requirements is to avoid pockets of stagnant air and provide unimpeded pathways for excess water vapour to escape.

Low level openings should be greater than high level openings to ensure fresh air is drawn from the outside and not from the living space.

For pitched roofs with a large airspace, low level (eave) ventilation openings allow entry of outside air and provide crossflow. High level (ridge) ventilation openings allow escape of the warm moist air.

Table 10.8.3 Roof space ventilation requirements

Roof Pitch	Ventilation Openings
< 10°	25,000 mm ² /m provided at each of two opposing ends
≥ 10° and < 15°	25,000 mm ² /m provided at the eaves and 5,000 mm ² /m at high level
≥ 15° and < 75°	7,000 mm ² /m provided at the eaves and 5,000 mm ² /m at high level, plus an additional 18,000 mm ² /m at the eaves if the roof has a cathedral ceiling

Table Notes:

1. Ventilation openings are specified as a minimum free open area per metre length of the longest horizontal dimension of the roof.
2. For the purposes of this Table, high level openings are openings provided at the ridge or not more than 900 mm below the ridge or highest point of the roof space, measured vertically.

APPLYING THE ROOF SPACE VENTILATION REQUIREMENTS

Common roof systems in Australian housing, such as profiled corrugated steel and tiled roofing, have traditionally provided weatherproofing and durability. Roof ventilation provisions apply to both steel and tiled roof types in both standard pitch truss roofs and skillion or cathedral roof systems.

Roof systems are being built up to provide energy efficiency, condensation risk mitigation, bushfire protection and protection from the elements. Roof insulation and reflective thermal membranes provide energy efficiency, condensation risk mitigation and can be used for bushfire ember protection in steel roofs. Sarking can be used for water control and bushfire ember protection.

Ventilation approaches will be influenced by:

- Roof type
- Roof design
- Insulation/membrane selection and detailing.
- Ventilation device options for low or high level available.

Roof space ventilation is not required for roofs made of insulated sandwich panels or a roof that is subject to Bushfire Attack Level FZ in accordance with AS3959.



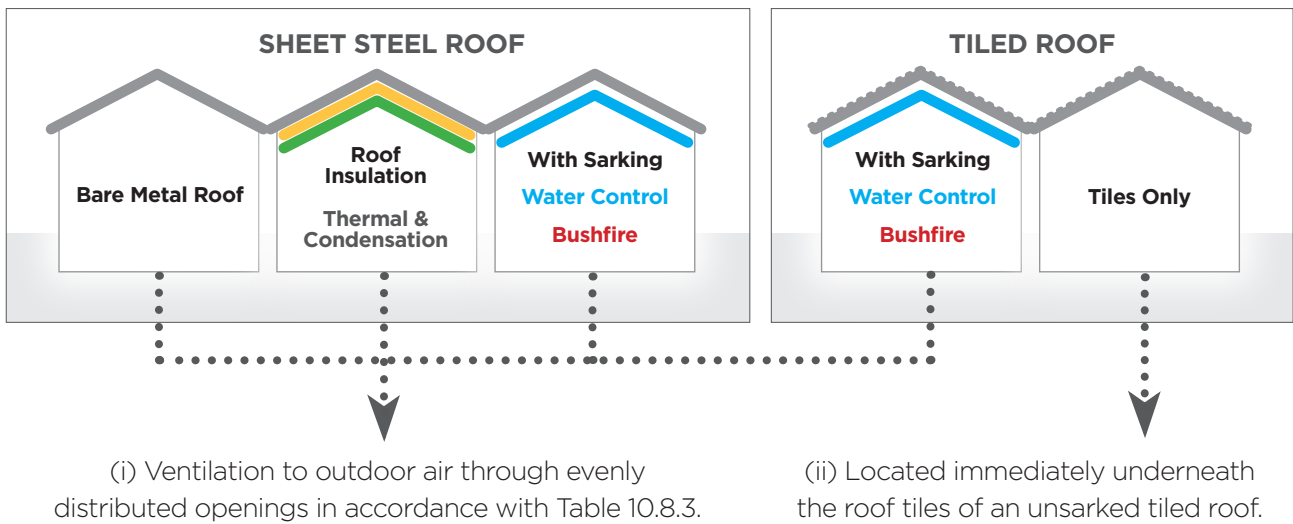

APPLICATION OF VENTILATION TO DIFFERENT ROOF SYSTEMS

Different roof designs and systems require different ventilation approaches.

Roof Insulation such as blanket and foil or reflective membranes when installed for thermal and condensation control requires a vapour barrier and rely on ventilation of the roof space below the membrane to facilitate drying (refer Figure 1).

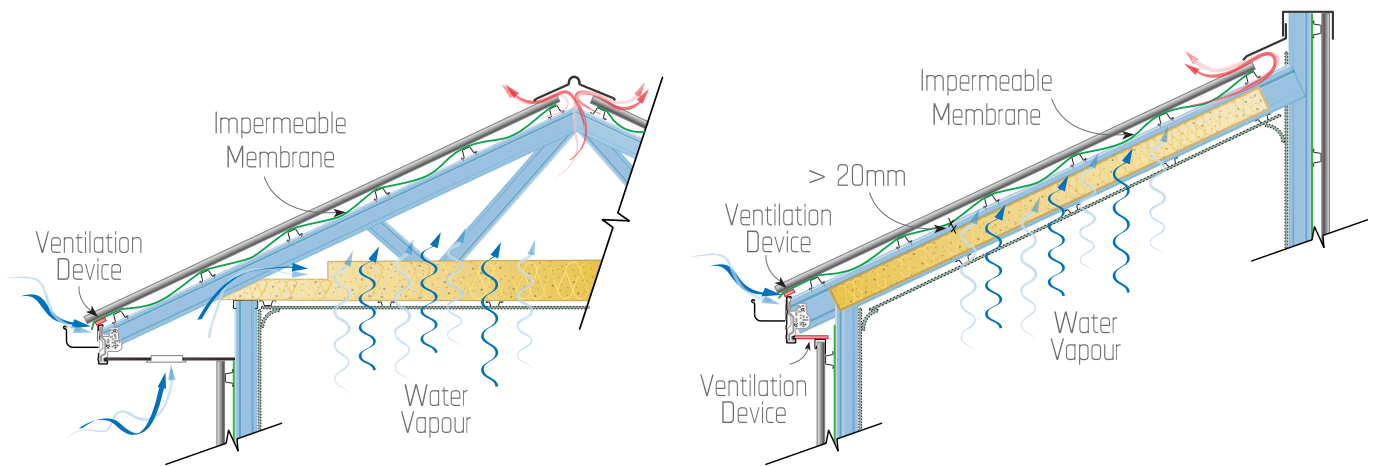

FIG 1(a) Pitched roof with a flat ceiling

FIG 1(b) Skillion roof

Figure 1 – Ventilation below the impermeable membrane facilitates drying of the roof space.

Reflective membranes can act as a sarking (secondary water control) or for ember protection (bushfire). These can be a vapour barrier or a permeable membrane.

Permeable membranes allow the free passage of water vapour into the air space between the membrane and underside of the roof sheet. When a permeable membrane is used in a typical pitched roof, the NCC DtS requires roof space ventilation below the membrane. This system also requires above membrane ventilation and free drainage to the gutter - see Figure 2. Part 10.8.3.1 (a)(ii) states that when a pliable building membrane is installed immediately on top of the ceiling insulation then it must be vapour permeable (AS4200.1:2017 - Class 4).



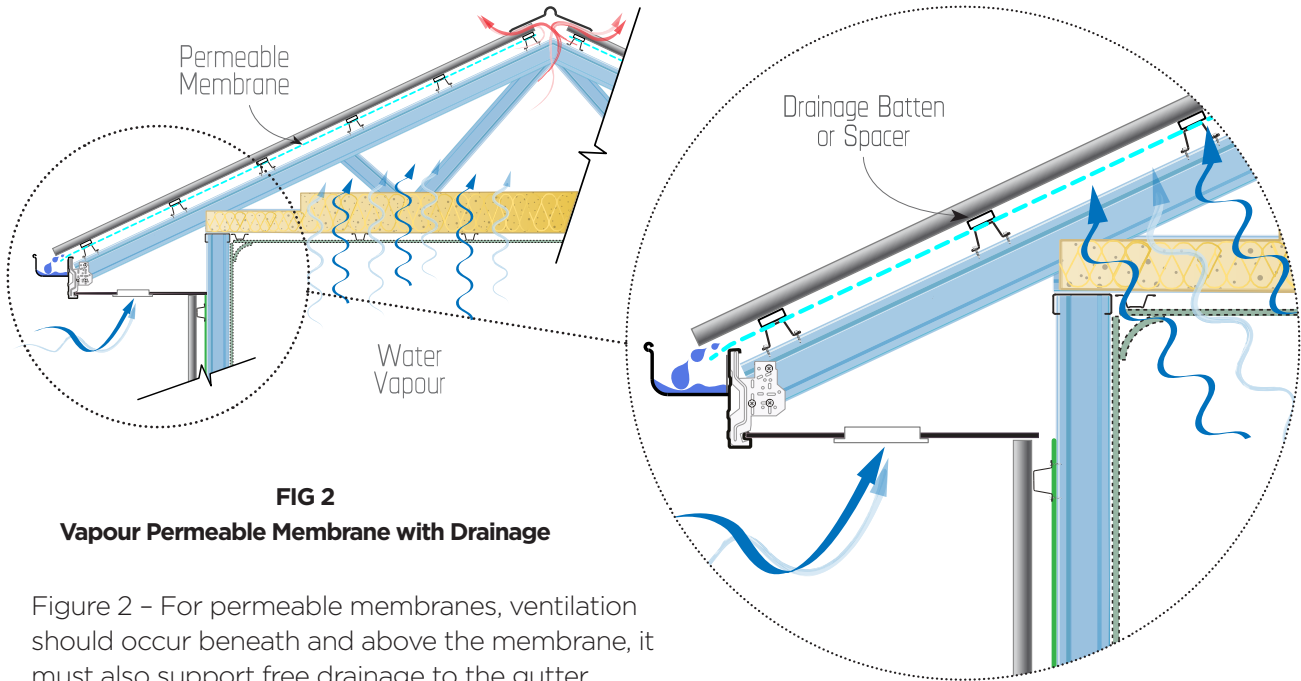

FIG 2
Vapour Permeable Membrane with Drainage

Figure 2 – For permeable membranes, ventilation should occur beneath and above the membrane, it must also support free drainage to the gutter.

Additional design and detailing considerations are necessary where permeable membranes are applied directly beneath steel roofing to ensure that moisture can escape and the durability of components are maintained.- refer to “Condensation Management for Steel Roofing - Principles and approaches for managing moisture in Australian residential steel roof systems” in this series for further information.

DETERMINING VENTILATION OPENING REQUIREMENT AT LOW AND HIGH LEVEL

The total roof ventilation opening requirement is specified as a minimum opening area (mm^2) per length (m) of the longest horizontal dimension of the roof.

The longest horizontal dimension and the roof pitch determines the total ventilation opening requirement at low and high level.

The following roof schematics are provided to assist interpretation of Table 10.8.3.

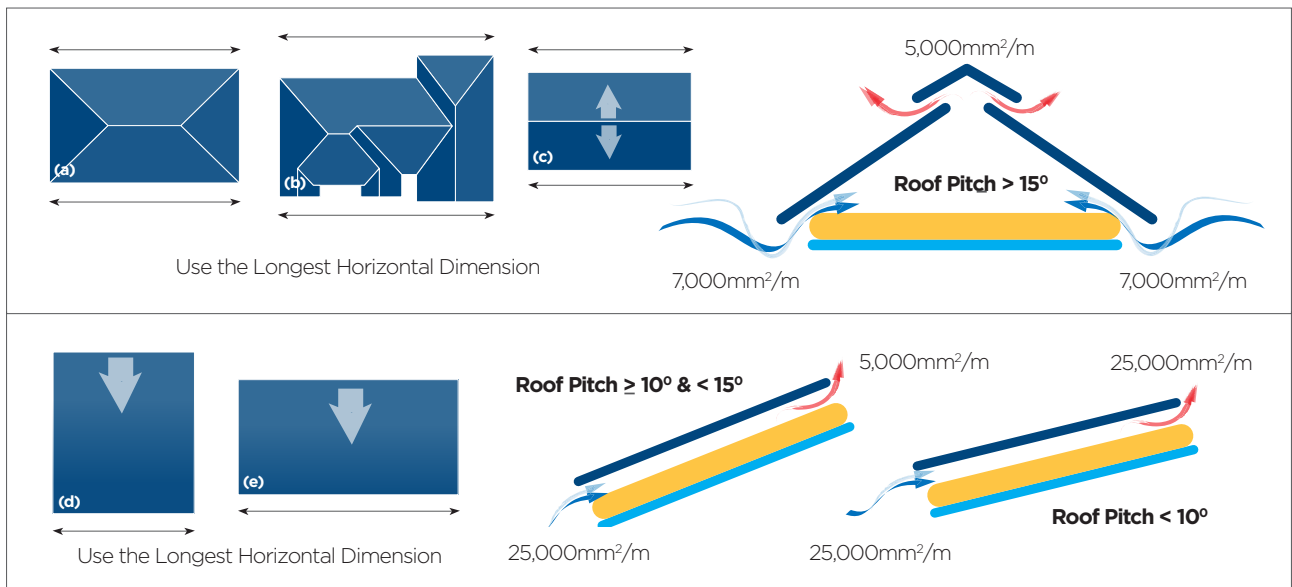
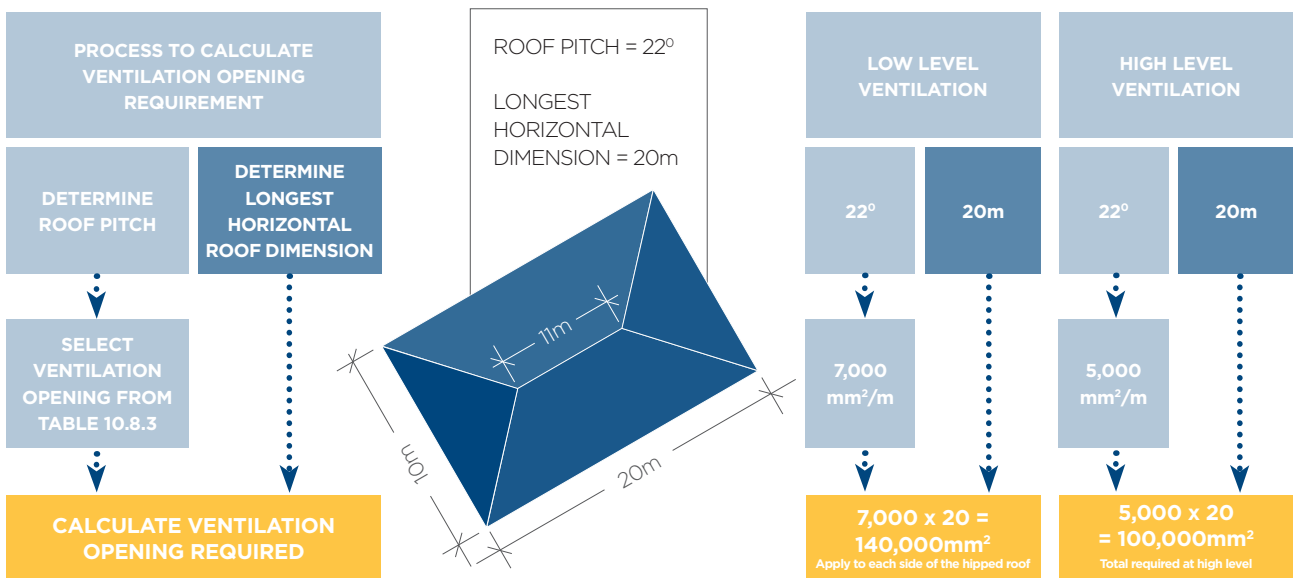

FIG 3 - (a & b) hipped roof, (b & c) gabled roof, (d & e) single planed skillion roof.

The total openings for hipped or gable roofs should be calculated from the longest horizontal dimension and applied to at least two of the sides. For single planed roof types, apply to only the lower, longer side.

To determine the required ventilation opening area the specified opening requirement needs to be multiplied by the length of the horizontal dimension. Below is a worked example:



Typical steel roofing systems can provide access to multiple pathways for low and high level ventilation, providing design and installation flexibility. To meet the ventilation opening area a single pathway or multiple pathways can be combined. Refer to the examples below:

LOW LEVEL EAVE ventilation required can be achieved by:

- 1a - soffit ventilation, or
- 1b - over fascia ventilation, or
- A combination of 1a + 1b

HIGH LEVEL ventilation required can be achieved by:

- 2a - soffit ventilation, or
- 2b - high level ventilation, or
- A combination of 2a + 2b

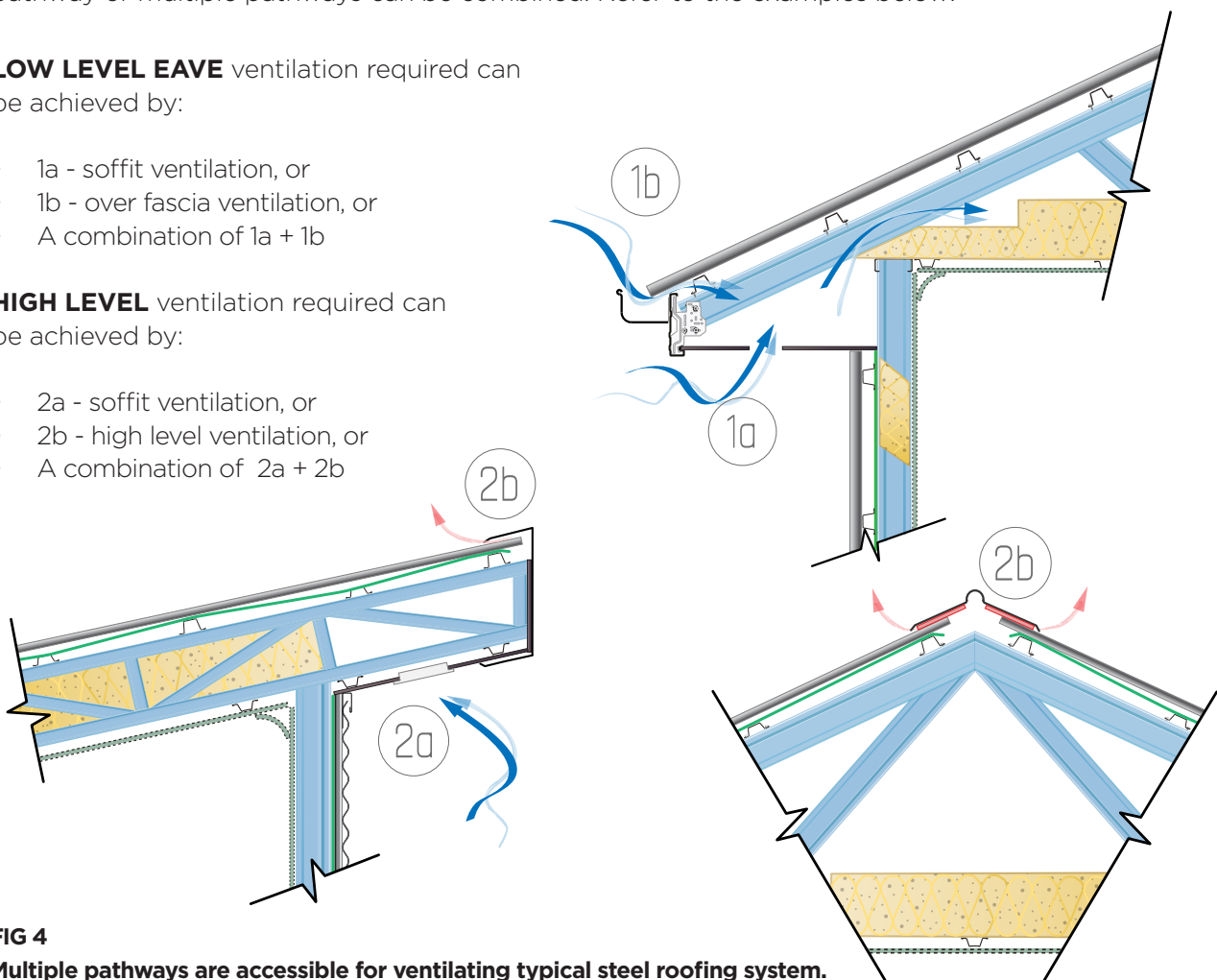

DISTRIBUTION OF VENTILATION OPENINGS.

Ventilation is required to be distributed evenly around the roof as much as possible. This can be achieved via continuous ventilation opening at eaves and ridges, including the inherent openings in profiled steel roofing, or via evenly distributed ventilation accessories at the eave level.

Vent distribution should ensure there are no dead air spaces in the roof or stagnant air. Vent distribution should aim to achieve cross flow

ventilation across opposing sides of the roof and minimise pockets of stagnant air.

High level ventilation is required at ridges or not more than 900mm from a ridge. In situations where there is insufficient ridge to meet the high level ventilation opening requirement, options could include: vent device or utilising hips within 900mm from the ridge.

VENTILATION OPTIONS TO ACHIEVE COMPLIANCE

ACCESSIBLE VENTILATION OPENINGS IN STEEL ROOFING PROFILES

The area between a corrugated steel profile and an adjacent flat surface (e.g. a flashing) provides a free ventilation area exceeding a continuous 7mm slot.



Accessible ventilation exceeds $7000\text{mm}^2/\text{m}$

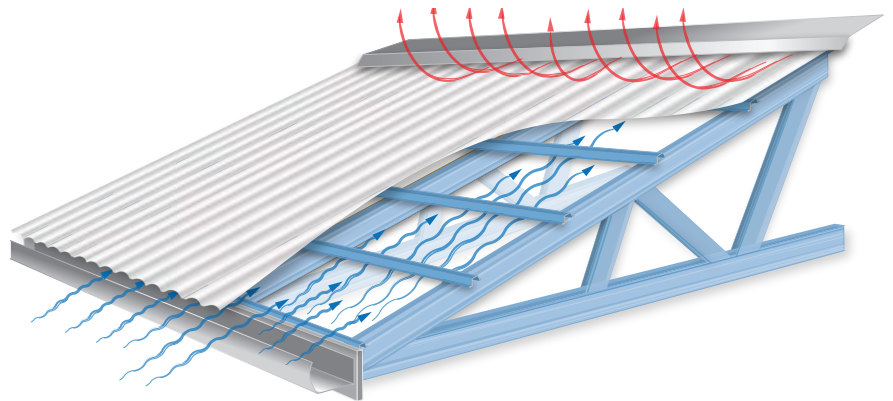

Open profile claddings are able to provide low and high level ventilation pathways. Examples include corrugated and trapezoidal profiles as shown below.

Profile Type	Low Level Ventilation	High Level Ventilation
Corrugated	$7,500\text{mm}^2/\text{m}$	$7,500\text{mm}^2/\text{m}$
Trapezoidal	$6,500\text{mm}^2/\text{m}$	$21,000\text{mm}^2/\text{m}$
Close Pitched Trapezoidal	$11,000\text{mm}^2/\text{m}$	$12,000\text{mm}^2/\text{m}$

FIG 5 - Typical Australian open profile types - with low and high level ventilation opening.

Where ventilation pathways are accessed using profiled cladding openings, some considerations are:

a) Openings at an eave and ridge must be unobstructed. Ridge flashing and weatherproofing details (such as scribing) or infill strips that may restrict profile openings should be considered.

b) Where roof insulation is used for thermal and condensation purposes, high level ventilation

pathways can be achieved by terminating the membrane or blanket and foil at the ridge batten (refer Drawing 6)

c) Where a sarking is used for secondary water control, ventilation approaches underneath the membrane must maintain drying and drainage to the gutter.

Closed profiles, such as wide flat pan profiles inherently provide access to significant high-level ventilation opening.

VENTILATION DEVICES

Examples of vent devices that can provide additional levels of ventilation or pathways are set out below.

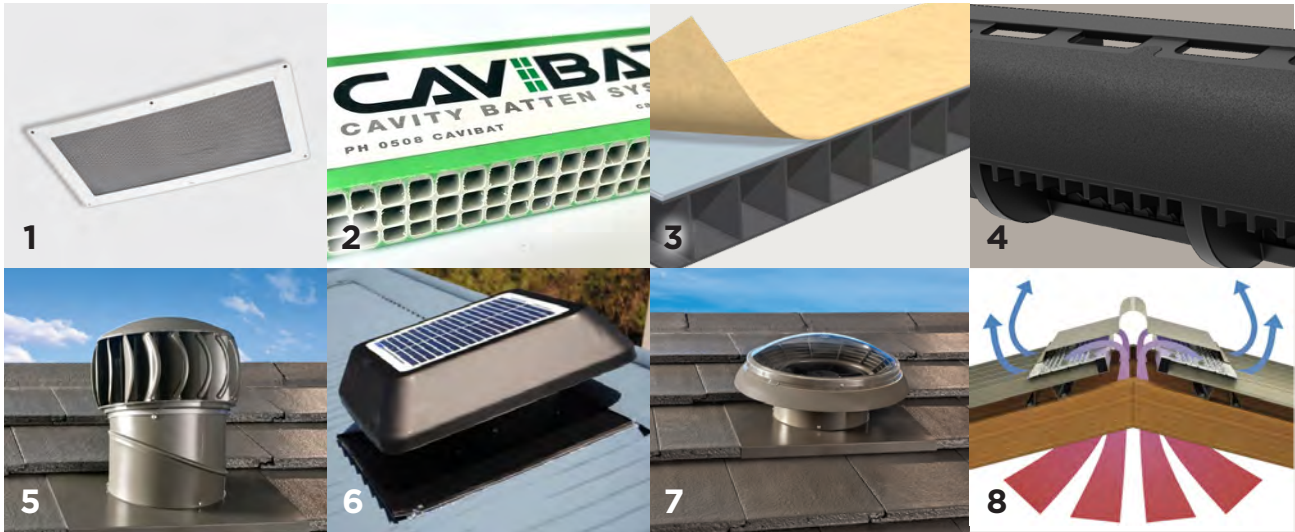

FIG 6 - Examples of vent devices.

1. Eave vents (pic: Bradford Eave Vent), **2. Cavity batten** (pic: Cavibat Cavity Batten), **3. Cavity Batten** (pic: VB20 Proctor Ventilated Batten), **4. Over fascia vents** (pic: FV25 ProctorVent Over Fascia Vent), **5. Mechanical ventilators e.g. Whirlybirds** (pic: Bradford WindMaster), **6. Solar fans** (pic: Bradford SolarXVENT), **7. Smart ventilators - with temperature and/or humidity sensors** (pic: Bradford AiroMatic), **8. Ridge vents** (pic: Lysaght Vent-a-roof®)

Ventilation devices such as cavity battens, over fascia vents, ridge vents or custom flashings with integrated ventilation can be used effectively to ventilate a roof system. Accessories are often used as a part of a roof system for pest and vermin control, bushfire protection, weatherproofing and corrosion protection in marine areas. These can impact or be used to maintain ventilation of the roof space.

Meshes can be used for roofs in bushfire zones (ember protection), salt aerosol protection in marine zones and protections from vermin and pests. These meshes typically have low resistance to airflow and can still be applied where required.

Ventilation devices such as cavity battens, drainage battens, ridge vents and fascia vents are acceptable provided they do not create excessive resistance to airflow.

When considering accessories for ventilation devices in a steel roof system there are some following considerations:

- Compatibility with steel roofing components.
- Must be thermally stable for steel roofing service conditions.
- Vent device must be installed and maintained to ensure effective air flow.

Common building performance interactions that require special attention in relation to vents include:

- The vent device must be vermin and pest proof.

Durability considerations when ventilating roof spaces in accordance with NCC2022 requirements in marine zones:

- Ventilation devices in marine zones should be constructed from suitable materials for the service conditions. Maintenance of ventilation devices in marine zones should be considered.
- Construction should consider the protection and/or durability of components especially those in close proximity to ventilation openings.

Fundamental approaches to mitigate aerosol migration into building cavities can be achieved by:

- Meshes with aperture less than 2mm.
- Convolved pathways

In addition to these approaches, seek manufacturers advice where available. An example of this is Bluescope Technical Bulletin TB-34: Steel Building Frames. This provides guidance on practices to separate the frame from the exterior environment in relation to the distance from different marine conditions.

The ventilation device may need to comply with bushfire requirements:

- BAL12.5 to BAL40 - have meshed ventilation paths with apertures no larger than 2mm (AS3959) Bushfire.
- Ventilation devices should be rated for the BAL zone and non-combustible.

GUIDANCE ON VENTILATION PATHWAY OPTIONS

Examples of ventilation details and options for typical Australian residential applications where open steel roofing profiles are installed are provided here.

If constructing in Bushfire zones to AS3959, mesh may be required.

Roof Pitch	Primary Membrane Function					Ventilation Type	Drawing Example	Ventilation device for trussed roof
	Thermal & Condensation	Water Control	Eave Vent	Profile Aperture	Ventilation Device			
15-75 degrees LOW level Ventilation Impermeable Membrane*	✓	✓	✓				Dwg 1	Eave ventilation for trussed roof
		✓				✓	Dwg 2	Ventilation device for trussed roof
		✓				✓	Dwg 3	Ventilation device for eaveless trussed roof
	✓	✓				✓	Dwg 4	Ventilation device for eaveless trussed roof
10-75 degrees HIGH level Ventilation Impermeable Membrane*	✓			✓			Dwg 5	Profile ventilation for trussed roof
	✓					✓	Dwg 6	Ventilation device for trussed roof
	✓					✓	Dwg 7	Ventilation device for trussed roof
	✓					✓	Dwg 8	Ventilation device for trussed roof/parapet
0-15 degrees LOW level Ventilation Impermeable Membrane*		✓					Dwg 9	Ventilation device for skillion roof
		✓				✓	Dwg 10	Ventilation device for skillion roof
	✓	✓		✓		✓	Dwg 11	Ventilation device for eaveless skillion roof
10-15 degrees HIGH level Ventilation Impermeable Membrane*	✓					✓	Dwg 12	Profile ventilation for skillion roof
		✓				✓	Dwg 13	Ventilation device for skillion roof
	✓					✓	Dwg 14	Ventilation device for skillion roof
	✓					✓	Dwg 15	Eave ventilation for skillion roof
10-75 degrees LOW level Ventilation Permeable Membrane**		✓				✓	Dwg 16	Eave ventilation for trussed roof
		✓				✓	Dwg 17	Ventilation device for eaveless skillion roof
10-75 degrees HIGH level Ventilation Permeable Membrane**		✓				✓	Dwg 18	Ventilation device for trussed roof
15-75 degrees LOW level Ventilation Impermeable Membrane*	✓						Dwg 19	Profile ventilation for eaveless trussed roof

*Membranes are deemed impermeable if they are classified as Class 1 or 2 as per AS4200.1. Blanket and foil with the membrane classified as Class 1 or 2 are also deemed suitable.

** Permeable membranes for roofing are Class 4 as per AS4200.1.

Permeable membranes are not recommended for roof pitches below 10 degrees due to the inability to drain at lower pitches.

VENTILATION APPROACHES

Dwg 1. Eave Ventilation for Trussed Roof

Pitch: 15-75 degrees | Ventilation: Low Level
Ventilation Opening req: 7,000mm²/m

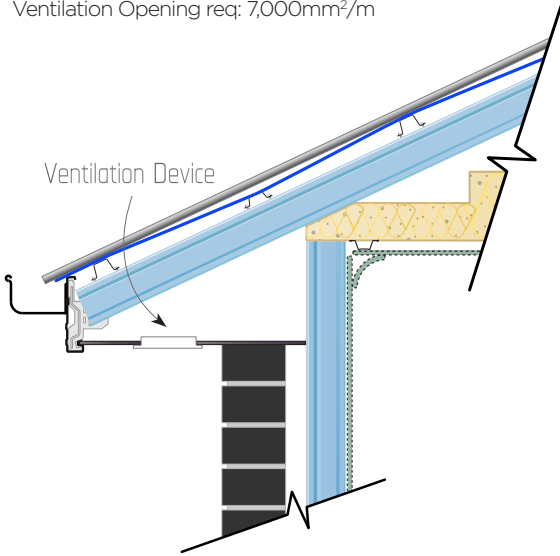

Dwg 2. Ventilation Device for Trussed Roof

Pitch: 15-75 degrees | Ventilation: Low Level
Ventilation Opening req: 7,000mm²/m

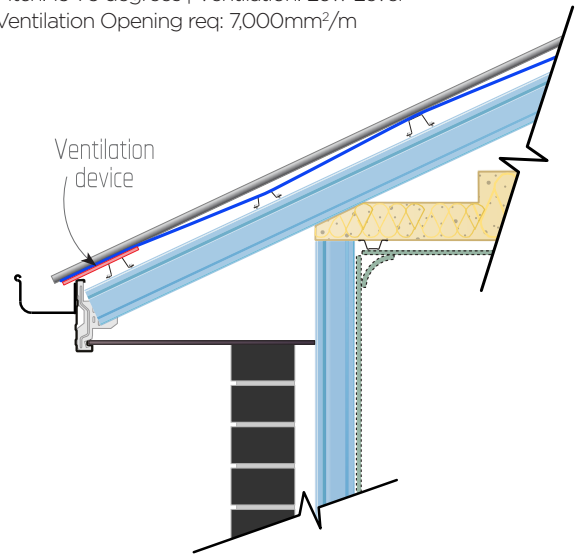

Dwg 3. Ventilation Device for Eaveless Trussed Roof

Pitch: 15-75 degrees | Ventilation: Low Level
Ventilation Opening req: 7,000mm²/m

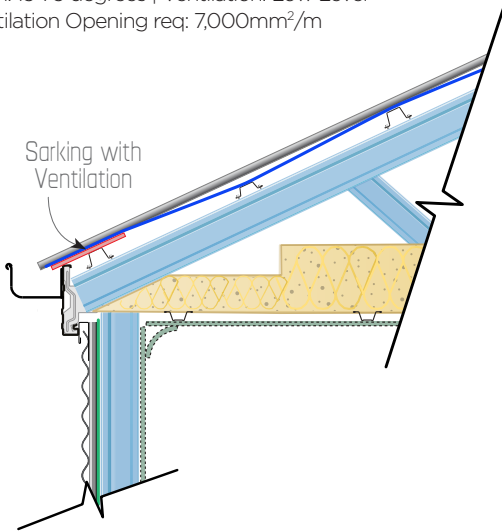

Dwg 4. Ventilation Device for Eaveless Trussed Roof

Pitch: 15-75 degrees | Ventilation: Low Level
Ventilation Opening req: 7,000mm²/m

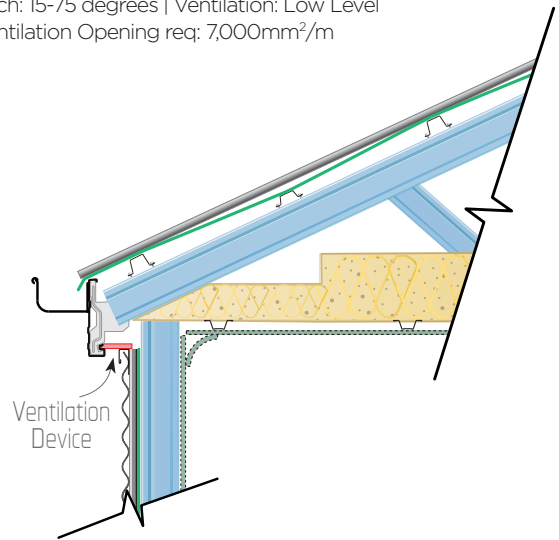

Dwg 5. Profile Ventilation for Trussed Roof

Pitch: 10-75 degrees | Ventilation: High Level
Ventilation Opening req: 5,000mm²/m

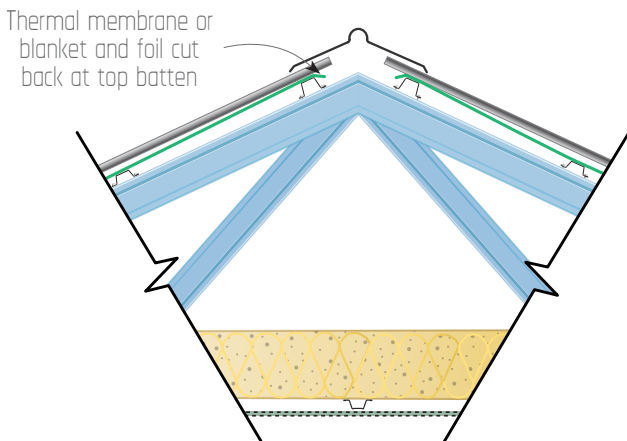

Dwg 6. Ventilation Device for Trussed Roof

Pitch: 10-75 degrees | Ventilation: High Level
Ventilation Opening req: 5,000mm²/m

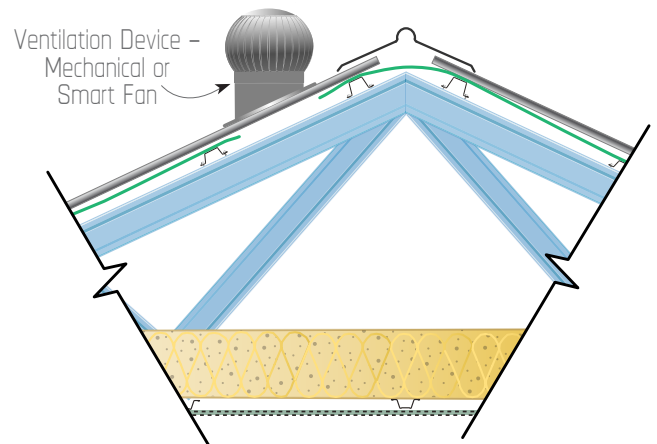

Dwg 7. Ventilation Device for Trussed Roof

Pitch: 10-75 degrees | Ventilation: High Level
Ventilation Opening req: 5,000mm²/m

Ventilation Device or Ridge
Ventilation Roof Insulation or
Thermal Membrane cut back
at top batten

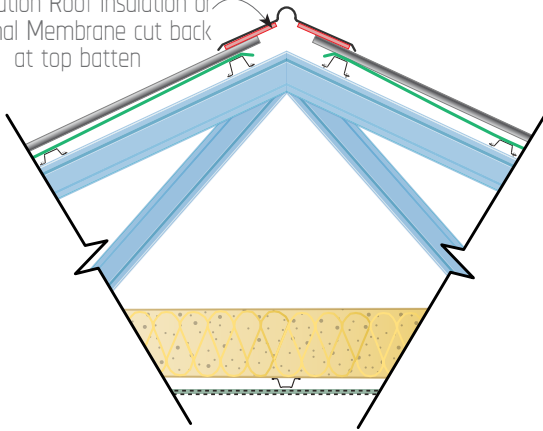

Dwg 8. Ventilation Device for Trussed Roof/Parapet

Pitch: 10-75 degrees | Ventilation: High Level
Ventilation Opening req: 5,000mm²/m

Ventilation Device
Roof Insulation or Thermal
Membrane cut back at top
batten

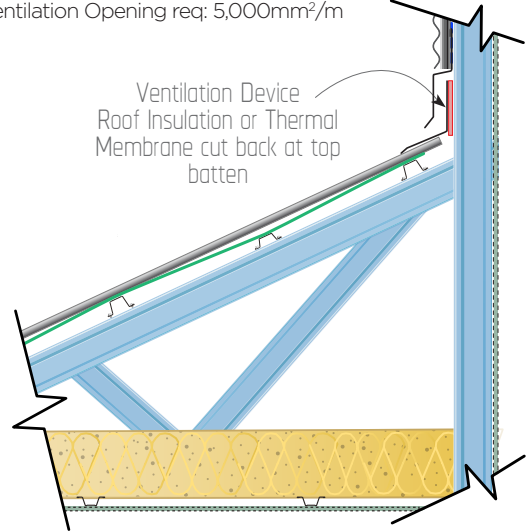

Dwg 9. Ventilation Device for Skillion Roof

Pitch: 0-15 degrees | Ventilation: Low Level
Ventilation Opening req: 25,000mm²/m

Ventilation Device

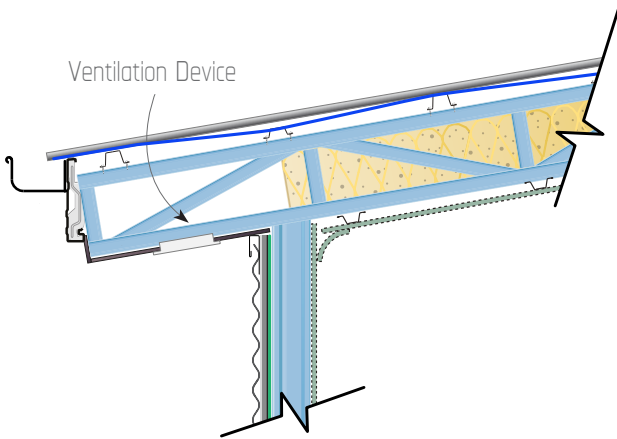

Dwg 10. Ventilation Device for Skillion Roof

Pitch: 0-15 degrees | Ventilation: Low Level
Ventilation Opening req: 25,000mm²/m

Ventilation Device

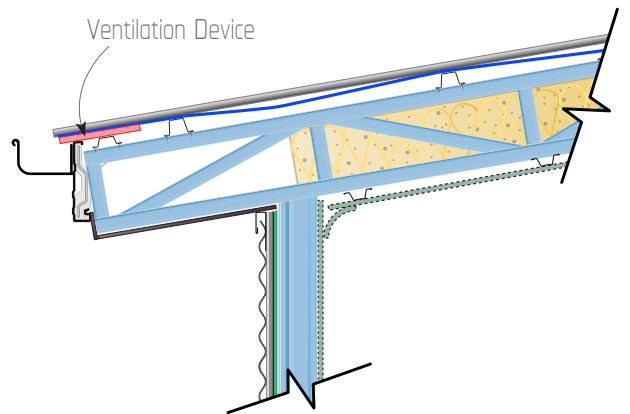

Dwg 11. Ventilation Device for Eaveless Skillion Roof

Pitch: 0-15 degrees | Ventilation: Low Level
Ventilation Opening req: 25,000mm²/m

Ventilation
Device

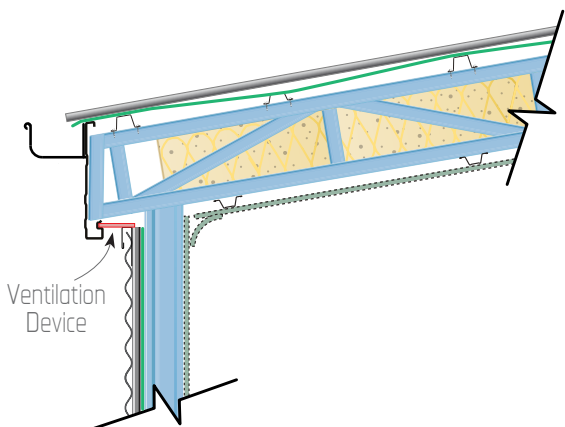

Dwg 12. Profile Ventilation for Skillion Roof

Pitch: 10-15 degrees | Ventilation: High Level
Ventilation Opening req: 5,000mm²/m

Roof Insulation or
Thermal Membrane cut
back at top batten

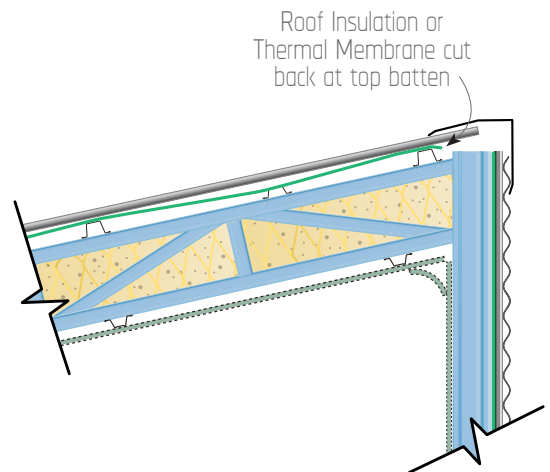

Dwg 13. Ventilation Device for Skillion Roof

Pitch: 10-15 degrees | Ventilation: High Level
Ventilation Opening req: 5,000mm²/m

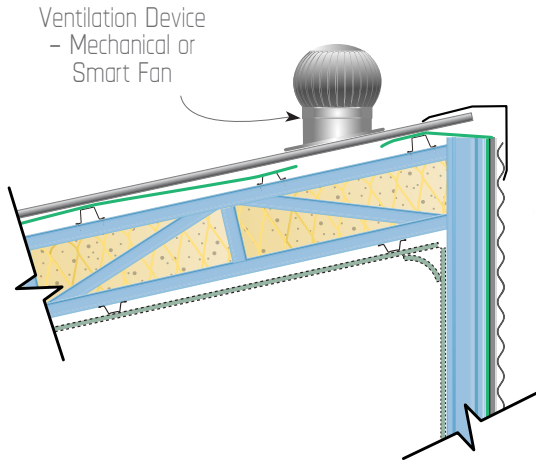

Dwg 14. Ventilation Device for Skillion Roof

Pitch: 10-15 degrees | Ventilation: High Level
Ventilation Opening req: 5,000mm²/m

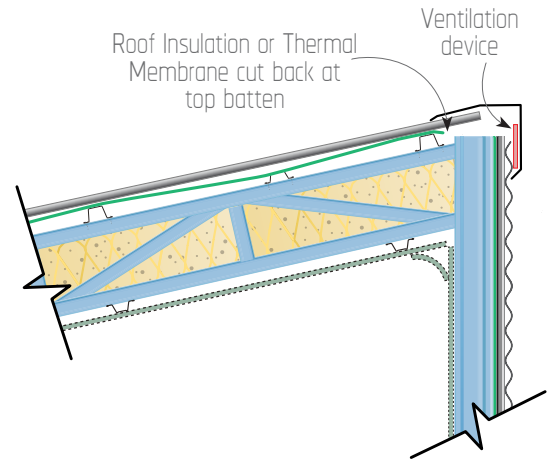

Dwg 15. Ventilation Device for Skillion Roof

Pitch: 10-15 degrees | Ventilation: High Level
Ventilation Opening req: 5,000mm²/m

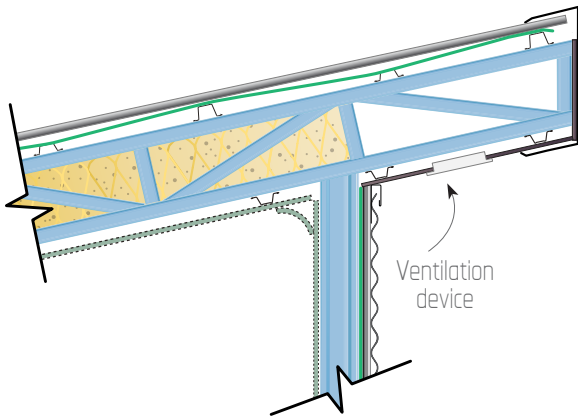

Dwg 16. Ventilation Device for Skillion Roof

Pitch: 10-75 degrees | Ventilation: Low Level
Ventilation Opening req: 7,000mm²/m

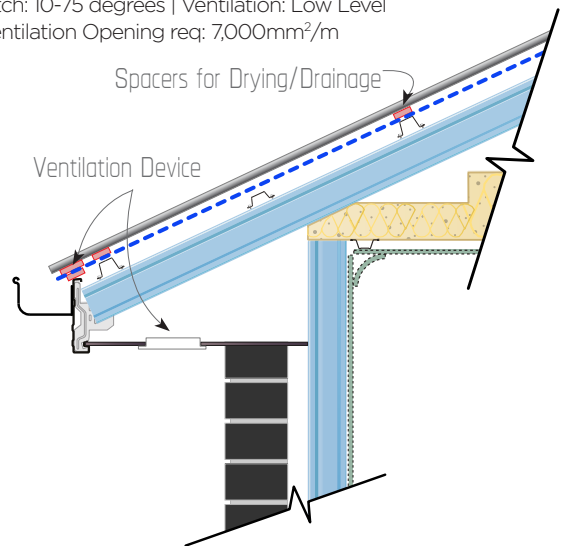

Dwg 17. Ventilation Device for Eaveless Skillion Roof

Pitch: 0-15 degrees | Ventilation: Low Level
Ventilation Opening req: 25,000mm²/m

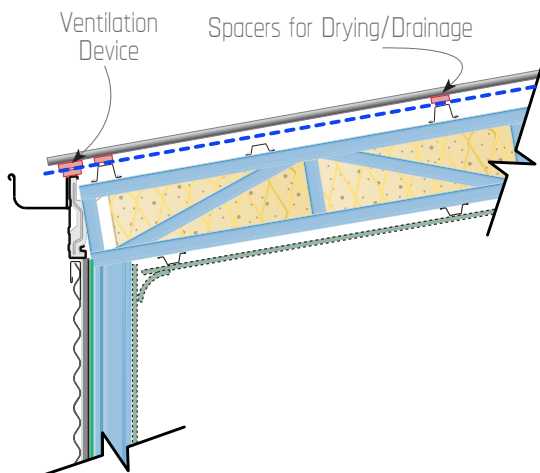

Dwg 18. Ventilation Device for Trussed Roof

Pitch: 10-75 degrees | Ventilation: High Level
Ventilation Opening req: 5,000mm²/m

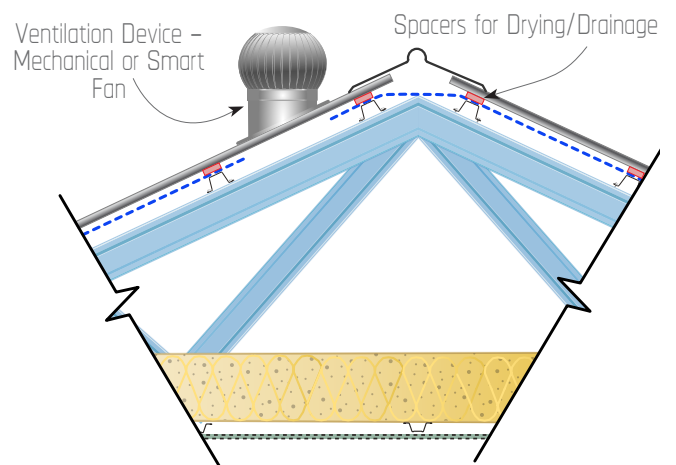

Dwg 19. Ventilation Device for Trussed roof - Zero Lot

Pitch: 15-75 degrees | Ventilation: Low Level
Ventilation Opening req: 7,000mm²/m

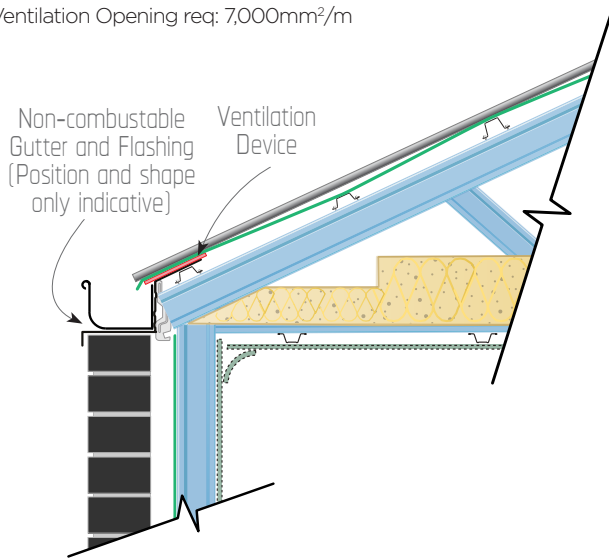

DEFINITIONS

- Blanket and Foil - Insulation product installed under cladding (typically roofs) consisting of a layer of bulk insulation adhered to a vapour impermeable reflective membrane.
- Condensation - is when water changes state from a vapour into a liquid. For condensation to occur it requires water vapour in the air and a cold surface to form onto.
- Free Drainage - a weatherproofing design mechanism that collects and redirects water away from the building envelope. Effective free drainage requires clear pathways from water to run to its intended destination.
- Meshes - a durable woven or punctured substrate that is often used to impede embers, salt aerosols or leaves while allowing the passage of air.
- Primary Insulation Layer - The most interior insulation layer of a roof construction (e.g. ceiling insulation).
- Reflective Thermal Membrane - A membrane with a surface emissivity and/or material R-value intended to reduce heat transfer.
- Sarking - a membrane that is installed in roofs that acts as a drainage plane and may also act as a thermal membrane (reflective – i.e. low emittance). Can be impermeable membrane or permeable that must act as water barrier.
- Scribing - fitting one building part neatly to another. An example of this in roofing is cutting a corrugated profile in a ridge cap.
- Vapour Pemeable Membrane - A pliable building membrane that allows the transfer of water vapour across the membrane (typically Class 4 in roofs).
- Vent Device - an accessory that can contribute to the ventilation opening requirements prescribed in the NCC.



NASH is an Australian industry association representing the interests of fabricators, material suppliers and customers of cold-formed steel structural framing systems for residential and similar construction. NASH develops Standards, Handbooks and Technical Notes for use by the industry and NASH Standards are referenced as Deemed-to-Satisfy solutions in the National Construction Code.

Contact NASH: +61 3 9809 1333
info@nash.asn.au
visit: www.nash.asn.au



AUSTRALIAN STEEL INSTITUTE

The Voice of Australian Steel

The Australian Steel Institute (ASI) is the nation's peak body representing the entire Australian steel supply chain from the manufacturing mills right through to end users in building and construction, heavy engineering and manufacturing.

Disclaimer

The information presented by the ASI, NASH and BlueScope Steel Limited has been sourced and prepared for general information only and does not in any way constitute recommendations or professional advice to any person for any purpose. While every effort has been made and all reasonable care taken to ensure the information contained is accurate and current, this information should not be used or relied upon for any specific application without investigation and verification as to its accuracy, currency, completeness, suitability and applicability by a competent professional person.

The Australian Steel Institute Limited, National Association of Steel Framed Housing Inc. and BlueScope Steel Limited, its officers, employees, consultants and contractors and the authors and editors of the publications contained on this website do not give any warranties or make any representations in relation to the information provided herein and to the extent permitted by law (a) will not be held liable or responsible in any way and (b) expressly disclaim any liability or responsibility for any loss, damage, costs or expenses incurred in connection with this limitation, including loss, damage, costs and expenses incurred as a result of the negligence of the officers, employees, consultants, contractors, authors, editors or publishers.

Contact ASI: +61 2 8748 0180
enquiries@steel.org.au
visit: www.steel.org.au.

