

STEEL WALL CLADDING

Guidance on good practice and NCC2022 compliance for the installation of steel wall claddings in residential and commercial / industrial applications

SWC V20-INDUSTRY 23



AUSTRALIAN STEEL INSTITUTE

CONTENTS

DOCUMENT PURPOSE	2
NCC REQUIREMENTS FOR STEEL WALLING	3
COMPLIANCE PATHWAYS - WEATHERPROOFING	3
SECTION 1 - SINGLE SKINNED STEEL WALL CLADDINGS	4
BENEFITS OF STEEL WALL CLADDING	4
COMMON TYPES OF PROFILES	4
APPROACHES TO WEATHERPROOFING AND DRAINAGE	5
WEATHERPROOFING - INSTALLATION GOOD PRACTICE	6
TYPICAL FLASHING LOCATIONS AND TERMINOLOGY	6
CAVITIES, DRYING AND DRAINAGE INSTALLATION GOOD PRACTICE	7
ADDITIONAL GOOD PRACTICES	9
SECTION 2 - INSULATED SANDWICH PANELS	9
BENEFITS OF INSULATED SANDWICH PANELS	10
STORAGE AND HANDLING OF INSULATED SANDWICH PANELS	11
APPROACHES TO WEATHERPROOFING AND DRAINAGE	11
MITIGATION OF THERMAL EXTREMES	12
DEFINITIONS (RELEVANT TO SECTIONS 1 & 2)	12
APPENDIX A - SINGLE SKINNED STEEL WALL CLADDINGS (RELEVANT TO SECTION 1)	14
ASI & CONTACTS	17

DOCUMENT PURPOSE

The purpose of this document is to provide general guidance to designers and installers of steel wall cladding products on industry terminology and good practices.

Section 1 relates to more commonly installed “**single skin**” **steel wall claddings**. It provides guidance on good practices relating to weathertightness (including recommendations for minimum flashing covers), moisture management, and structural support of the wall cladding system with reference to NCC 2022 requirements for non-cyclonic areas. Examples of common installation details are provided in Appendix A.

Section 2 relates to **Insulated Sandwich Panels**. It provides guidance in relation to design, weatherproofing with reference to NCC 2022 requirements and onsite storage and handling.

For bushfire construction, condensation management and energy efficiency requirements, refer to other ASI documents in this series.



AUSTRALIAN STEEL INSTITUTE

NCC REQUIREMENTS FOR STEEL WALLING

The focus of this document is to provide guidance regarding compliance to meet NCC requirements with respect to:

- Weatherproofing
- Structural fixings

NCC requirements that impact the design and installation of steel wall claddings include:

- Energy Efficiency
- Construction in Bushfire Areas
- Condensation and Ventilation

Readers are directed to other documents in this series for guidance on the above topics.

COMPLIANCE PATHWAYS - WEATHERPROOFING

NCC2022 Performance requirements (F3P1 for NCC Volume One and H2P2 for NCC Volume Two) state that a roof and external wall (including openings around windows and doors) must prevent the penetration of water that could cause:

- (a) unhealthy or dangerous conditions, or loss of amenity for occupants; and
- (b) undue dampness or deterioration of building elements

There are two main pathways for demonstrating compliance with NCC weatherproofing requirements. One is by way of a Deemed-to-Satisfy (DtS) solution based on compliance with AS 1562.1 “Design and installation of metal roof and wall cladding” and the other is by way of a performance solution testing to AS/NZS 4284 “Testing of building facades”. These pathways (excepting for Building types Classes 7, 8 and 10) are illustrated in the below flowcharts:

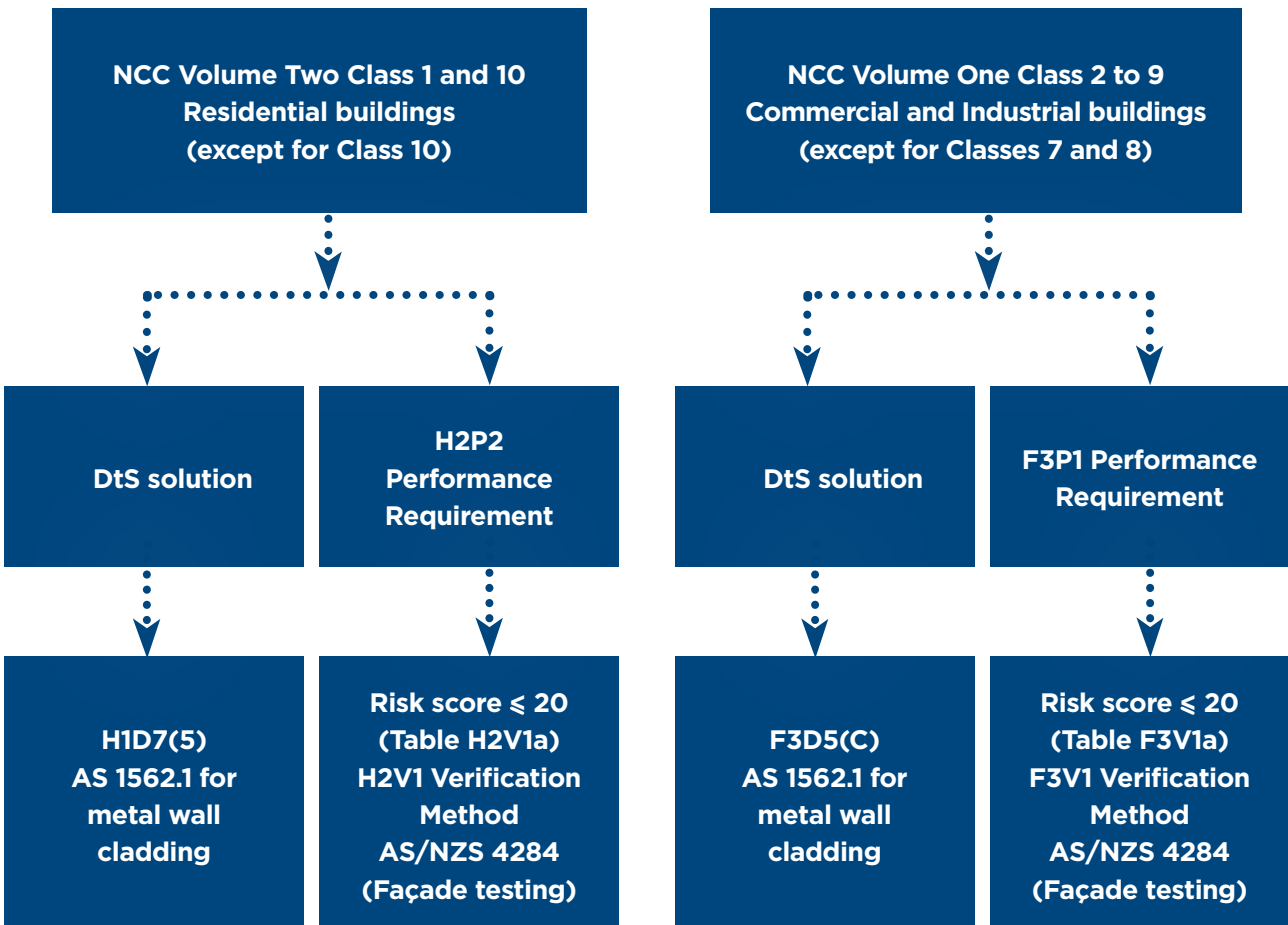

SECTION 1

SINGLE SKINNED STEEL WALL CLADDINGS

Single skinned products are the most commonly installed types of steel walling products. This section provides general guidance on good practices when designing and installing compliant single skin steel walling systems. Common installation details are provided in Appendix A of this document.

For bushfire related guidelines and more detailed energy efficiency requirements, it is advisable to refer to the other relevant ASI documents in this series. Note that this document does not substitute the installation guidelines provided by manufacturers for specific products or systems.

BENEFITS OF STEEL WALL CLADDING

Single skinned steel wall claddings are available in a range of profiles, finishes and colours featuring clean lines that complement both traditional and contemporary design looks.

In addition to their aesthetic appeal, single skinned steel wall claddings provide functional benefits with respect to weather resistance, durability and non-combustibility. Being lightweight, with good spanning ability, they can be installed quickly and easily with minimal waste. Steel also has the benefit of being recyclable for sustainable construction and can be an economical cladding option.



COMMON TYPES OF PROFILES

Corrugated profiles are well known due to being a popular choice for roof cladding as well as wall cladding. **Trapezoidal** profiles are also commonly used. Both corrugated and trapezoidal profiles have open ribs that allow airflow and are referred to as **“Open Profile Claddings”**.

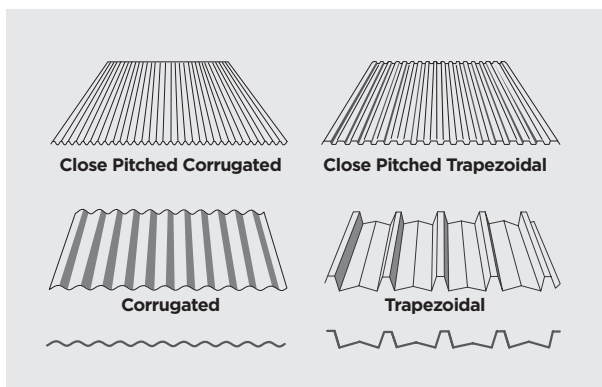

Over recent years, there has been growing awareness and popularity of what are often

referred to as **“Architectural profiles”**. These profiles have traditionally been made from copper and zinc materials, and have been associated with high end architectural applications. However the ability to manufacture with steel, and the cost advantage this offers, has seen an increased adoption by designers seeking a high end “look” that complements many new contemporary residential designs. **“Standing Seam”** is one such popular type of architectural profile, characterised by tight vertical ribs. Most architectural profiles are referred to as **“Closed Profile Claddings”** as underside airflow is restricted (and in some cases structural support is required).

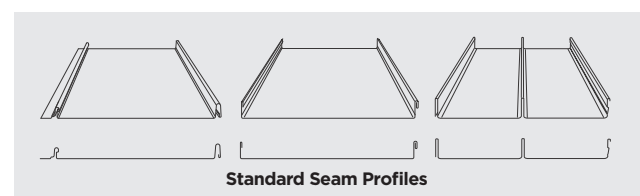

APPROACHES TO WEATHERPROOFING AND DRAINAGE

The key principles guiding weatherproofing for steel cladding can be summarised as the “4 D’s” – Deflection, Drainage, Drying and Durability.

Deflection: Steel wall claddings are impermeable to water and hence highly effective at deflecting external water away from the building. As with any cladding product, penetrations and joints across the building fabric need to be carefully designed to ensure external water is directed away from the building.

Drainage: Wall Cavities, with the assistance of gravity, can serve as effective pathways for drainage of unwanted water - both external (storm water) that has penetrated the building fabric, and internal moisture (interstitial) that needs to escape from the interior to the exterior of the building. Modern design and construction of steel cladding systems provides inherent gaps between components which facilitate drainage, air circulation and drying, and these are important for the weathertightness performance of the building.

Drying: Providing a cavity is considered good practice as it allows drying through air circulation and is assisted by temperature changes. Non-absorbent steel cladding and battens also allows for faster drying as compared to absorbent claddings and other building materials.

Durability: Normal construction tolerances provide sufficient drainage and drying while limiting marine aerosols from entering building cavities. It is essential that all components of wall systems are compatible. If not compatible, an impermeable barrier should be installed to isolate the incompatible components.

Preventing water entry and allowing drainage and drying can be assisted by the following construction options:

- Install flashings at the head, jamb and sill of all openings to drain water to the outside face of the cladding.
- Construct metal wall claddings with back-up systems such as underflashings/membranes at all junctions.
- Provide a drainage cavity.
- Maintain clearance where the bottom of the cladding terminates over any roof cladding, deck or apron/soaker flashing.
- Install air seals between window reveals and framing to reduce the risk of air leakage that can carry water past the cladding into the wall framing.

Detailing should prevent water entry in the first instance but should also make provision for the draining or drying out of any water that may penetrate under extreme weather conditions.*

**BlueScope Steel offers a number of technical bulletins to assist understanding of good construction practice and some of these are referenced later in this document.*



WEATHERPROOFING - INSTALLATION GOOD PRACTICE

Correct detailing and installation of flashings and membranes is key to weatherproofing a wall cladding system. The following drawing identifies key elements of the wall cladding system

that need to be correctly detailed and installed. Detailed drawings showing good industry practice installation of flashings and membranes is provided in Appendix A.

TYPICAL FLASHING LOCATIONS & TERMINOLOGY

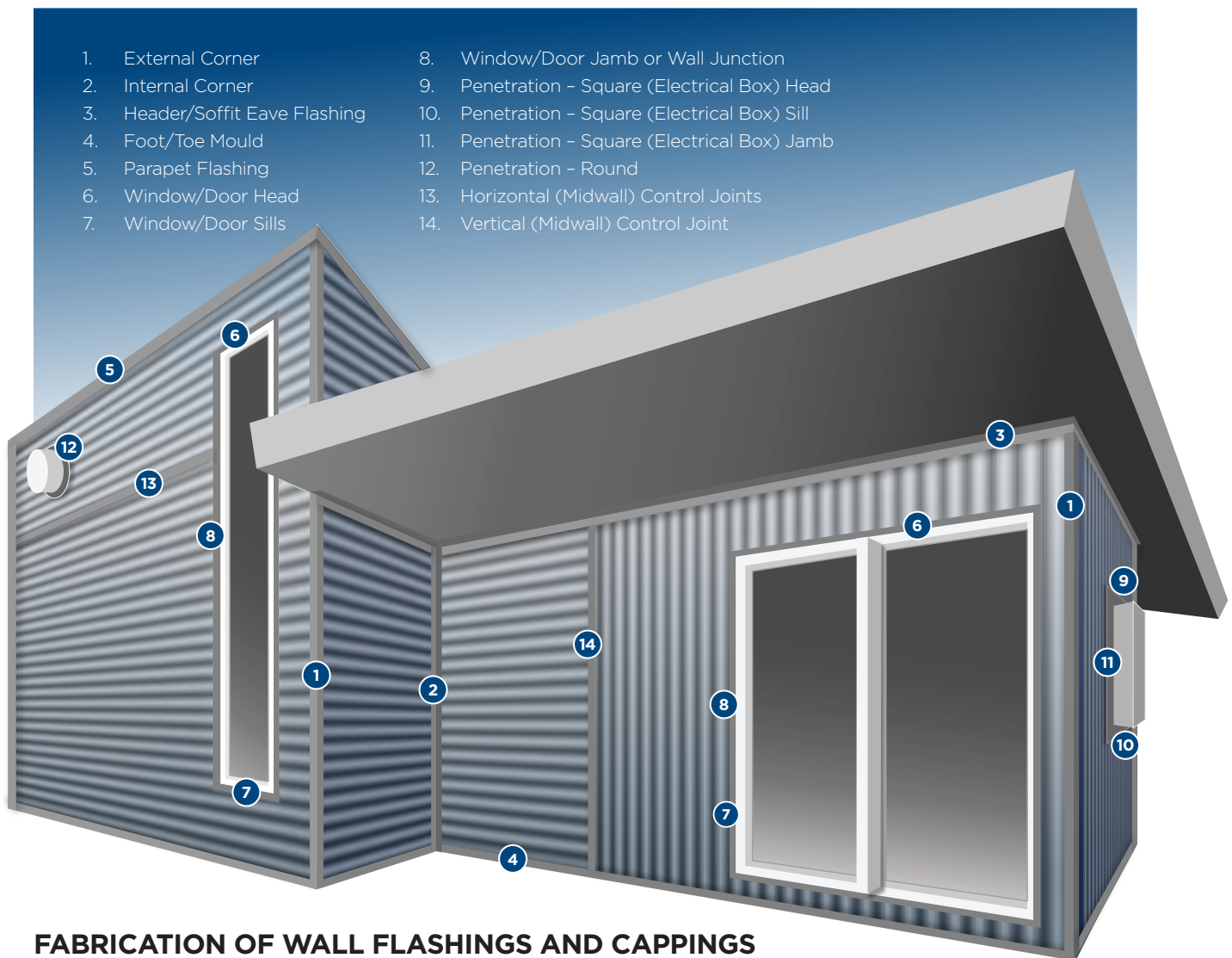

FABRICATION OF WALL FLASHINGS AND CAPPINGS

The following characteristics are considered general good practice for the fabrication of wall flashings and cappings:

- Typical flashing material Steel Grade G300 and Base Metal Thickness of 0.55mm.
- Angle tolerances of +/-2 degrees.
- Crush fold bends should have a minimum radius of 1.0mm Base Metal Thickness to avoid cracking. Length tolerances of +/- 15mm.
- Minimum horizontal angle for flashing drainage - 5 degrees (unless specified otherwise)
- Birds beak or Crush fold and turnout flashings are recommended for all exposed edges of horizontal flashings to divert storm-water, act as a drip propagator to avoid wall and window staining, and to deflect water from building. Refer to drawings in Appendix A.

FIXING FLASHINGS

The following characteristics are considered general good practice for the fastening of wall flashings when cladding is installed either horizontally or vertically

Cladding Orientation	Flashing Orientation	Type	Frequency
Vertical Cladding	Vertical Flashing	Self Drilling Screw/ Rivet	Not more than batten/girt spacing
	Horizontal Flashing	Self Drilling Screw/Rivet	At not more than 310mm centres
Horizontal cladding	Vertical Flashing	Self Drilling Screw/Rivet	At not more than 310mm centres
	Horizontal flashing	Self Drilling Screw/Rivet	Not more than batten/girt spacing

- Wall flashings and cappings to be tightly notched/scribed (where required) and fastened as per the table above. Where rivets are used in higher wind areas, capacity should be checked.
- Fasteners for pierce fixed claddings that are exposed to the weather should be installed with a seal.
- Joints in flashing and cappings to be 25mm (min) lap and fastened together at intervals not exceeding 40mm and silicon sealed with neutral cure silicon.
- Where rivets are used, refer to fastener manufacturer's recommendations.
- Parapet caps should avoid fixings on a horizontal surface.

USE OF FOAM FILLERS

Foam fillers used for weatherproofing are to be compatible with the cladding, durable and UV/temperature stable. Care should be taken that fillers (of all types) do not obscure intended drainage or drying paths.

CAVITIES, DRAINAGE AND DRYING - INSTALLATION GOOD PRACTICE

Best practice is to install steel wall claddings with a cavity rather than "direct fixing" to the frame. Cavities allow more effective drying and drainage and therefore improve durability of internal building components.

The cavity can be created via apertures inherent in the cladding, packers/ spacers (eg perforated) or via battens.

For metal framed construction, it is customary to have a 20mm cavity with reflective membrane.

While drying is assisted by provision of cavities incorporated into design and installation, drainage is achieved by installing pliable membranes and directing moisture over horizontal flashings. For all framed materials in Climate Zones 4 to 8, NCC2022 requires that the pliable membrane is to be vapour permeable (AS 4200.1 - Class 3 for Climate Zones 4 and 5, Class 4 for Climate Zones 4 to 8).

When battening out to create an air cavity, membrane should be fixed as per AS 4200.2 (i.e. for steel frames, mechanically fix with a broad headed washer at 300mm centres) prior to cladding, for timber frames fix at 150mm centres or follow manufacturer's guidance.

The cavity is not intended to be the primary drainage path. All pliable membranes and flashing must be designed to drain the water to the outside of the cladding.

For maximum flashed horizontal joints to drain, the cavity should not exceed 9m vertical height or in accordance with manufacturer's recommendation.

The following drawings shows the detail at bottom and head of walls that have vertical and horizontally installed steel cladding with open and closed profiles including drainage and drying pathways.

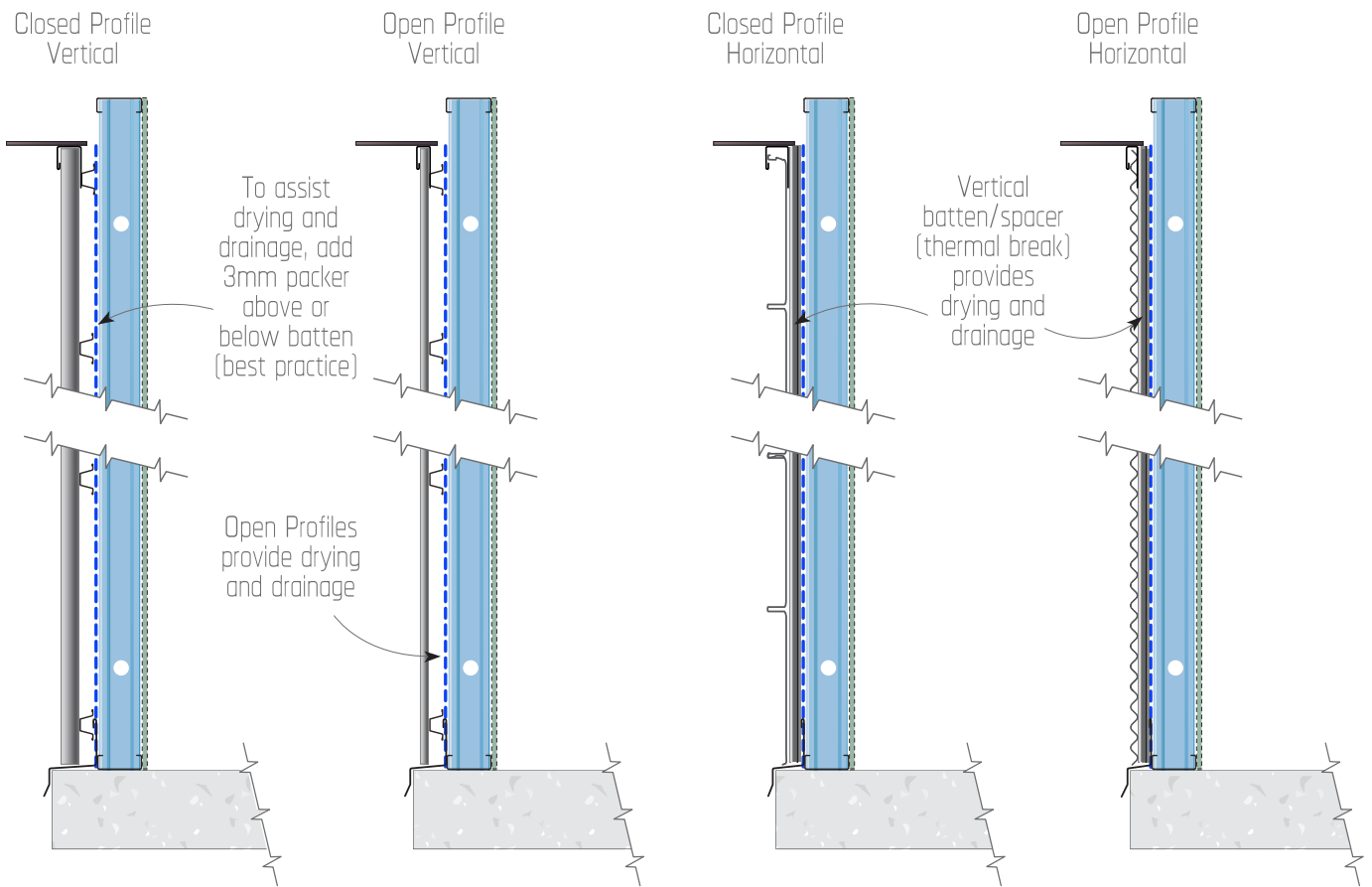

SUPPORT BATTENS

The following characteristics are considered general good practice when detailing and installing wall battens to provide optimal aesthetic and structural outcomes:

- Ceiling battens (0.42mm BMT) should not to be used for wall cladding applications unless approved by the cladding manufacturer or designed by an appropriate practitioner.
- To ensure a flat plane for installation of cladding panels, deviation across wall surface (batten top face) should not be more than 4mm across 2m (2mm/1 m or 1mm/500mm) when installed either vertically or horizontally.



- Thicker battens assist in achieving a dimensionally stable substructure
- Battens for wide pan cladding generally should be broad and flat and care should be taken to ensure these are installed square to the fixing plane.

RIGID SUPPORT

Rigid support materials may be recommended as part of cladding systems. Materials are commonly plywood or steel and/or are typically used to improve impact resistance, provide added support in cyclonic areas, and for aesthetic purposes (to reduce oil canning). Seek manufacturers's guidance regarding system detailing

ADDITIONAL GOOD PRACTICES

Aesthetics

- Any horizontal flashings should direct the water away from the cladding below to avoid staining. (Refer to Birds beak/crush fold kick outs in Appendix A).
- 3D mesh can be applied under wide pan claddings to minimise oil canning.

Clearances

- Keep a minimum 3mm clearance between exposed (visible) claddings with cut edges and other surfaces to provide a drip edge to enhance durability and minimise risk of corrosion.
- Where longer sheet lengths are required, clearance of both exposed visible and non exposed edges should be increased to accommodate thermal expansion/impedance.
- The DtS requirement in the ABCB Housing Provisions Part 7.5.7 relating to clearance between cladding and ground states that:
 - Clearance between bottom of sheeting to adjoining floor level is 100mm in well drained or low rainfall areas, 50mm for paving or concrete or other impermeable surface, or 150mm in all other cases. (Refer to diagrams in Appendix A).
 - Where there is a suspended floor, bottom of sheeting should be at least 50mm below the lowest horizontal part of the framing or bearer.

Unwashed areas

- Walling areas which are protected from rain require regular washing down to reduce corrosion. Refer to BlueScope Technical Bulletin 4 “Maintenance of exterior BlueScope coated steel products”.

Other Good Practice Guidance is provided in the following BlueScope Technical Bulletins:

- CTB - 12 - “Dissimilar Metals”
- CTB - 13 - “Steel in Contact with Timber”
- TB - 16 “Fasteners for roofing, walling and accessory product - selection guide”
- TB - 13 “General Guide to good practice in the use of exterior BlueScope coated steel products”
- TB - 40 “Guide to good practice - BlueScope coated steel products in exterior walling applications”

SECTION 2

INSULATED SANDWICH PANELS

Insulated sandwich panels (ISPs) are a composite building product consisting of two outer layers (skins) which are most often both steel and a layer of insulation (core) permanently bonded between them. In some instances, ISP’s will have one face of steel and the other face of vinyl, foil, paper, plywood or fibre cement.

The insulating core is typically of Expanded Polystyrene with Flame Retardant (EPS-FR), Phenolic modified Expanded Polystyrene, Polyurethane, Polyisocyanurate, or Mineral fibre.

This section offers general guidance for designers and installers working with ISP’s in relation to the design, storage, handling and weatherproofing compliance of residential and industrial ISP wall claddings with NCC 2022.

For bushfire related guidelines, condensation management and more detailed energy efficiency requirements, it is advisable to refer to the other relevant ASI documents in this series. Note that this document does not substitute the installation guidelines provided by manufacturers for specific products or systems.



TYPES OF CORE MATERIALS COMMONLY USED IN INSULATED SANDWICH PANELS

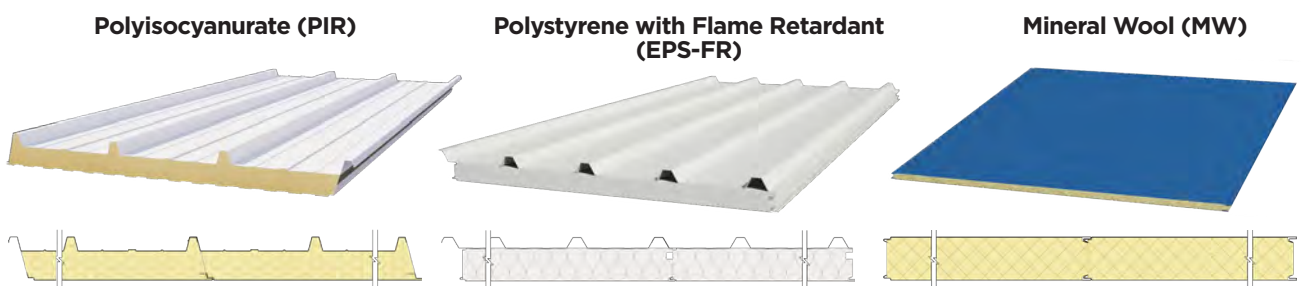

BENEFITS OF INSULATED SANDWICH PANELS

Insulated Sandwich Panels are known for their excellent weatherproofing properties.

One of the key advantages of ISPs is their ability to provide a tight and seamless building envelope. Panels are designed to interlock or overlap, minimising gaps and preventing air and water infiltration. This enhances the weatherproofing capability of the panels, ensuring that moisture, rain, wind, and other environmental elements are kept outside the building.

The insulating core provides thermal resistance, and together with a thermally broken panel joint, helps reduce heat transfer between the interior and exterior of the building. This helps to maintain a comfortable and energy-efficient indoor environment.

The continuous insulating core within the sandwich panel helps to reduce thermal bridging and maintain consistent temperatures throughout the panel. New NCC 2022 energy efficiency

provisions exempts ISP's from the thermal bridging mitigations introduced for residential applications. This information can be found in Volume Two Housing Provisions under 13.2.5(6), and in Volume One, under J3D6(2).

ISPs eliminate the necessity for cavities and building membranes, as the panel serves as an all-in-one wall system. In buildings which do incorporate cavity installed ISP walling, in contrast to conventional building practices, the temperatures inside the cavity and the building's interior are typically within a much closer range. This reduces significant temperature fluctuations, consequently minimising the risk of condensation.

However, it is important to note that in certain circumstances, condensation can still occur in ISP walls. Factors such as high humidity levels and inadequate ventilation can contribute to the potential for condensation formation and risk mitigation techniques should be employed.

STORAGE AND HANDLING OF INSULATED SANDWICH PANELS

Due to their stiffness and high rigidity, ISP's are usually produced in longer lengths to minimise the required number of laps in the wall cladding. Additionally, they are available in various core types, each with its own unique properties and features to suit each project's specific requirements. As a result, on-site handling of these panels requires specialised techniques.

Proper handling begins with appropriate on-site storage. It is crucial to store the panels on dry, level and solid ground and to protect them from exposure to the weather. Storing ISPs inside is preferred, and if stored outside ISPs should be completely covered with a waterproof covering.

As ISPs are thicker and heavier than single skin products of similar length, they require specific handling methods, and these can vary depending on the core material. Some core types such as non-combustible mineral wool are more prone to damage due to moisture, so more careful consideration of their storage and handling is required.

The strength of ISPs comes from the composite action of the outer skins and the insulating core. It is crucial to handle them carefully to maintain the integrity of these panels. Moreover, protecting the panel joints from damage is essential to ensure a secure fit. There are various mechanical lifting equipment options available, and the choice depends on factors such as the core type, panel thickness, weight, length of the panel, and the ground surface where the panels are being unloaded and handled on site. Following the manufacturer's guidelines on lifting equipment is imperative when working with these products.

The strength of ISPs comes from the composite action of the outer skins and the insulating core. It is crucial to handle them carefully to maintain the integrity of these panels.

APPROACHES TO WEATHERPROOFING AND DRAINAGE

To ensure the weatherproofing of walls constructed using ISP's, it is crucial to follow the design and installation guidelines provided by the manufacturer. Where documentation demonstrating compliance with AS 1562.1 is available, NCC2022's Deemed-to-Satisfy (DtS) pathway can be utilised. In cases where such documentation is not presented, alternative solutions, such as the Verification Method outlined in the "COMPLIANCE PATHWAYS - WEATHERPROOFING" section of this document, may be pursued.

Selection of appropriate fasteners and washers is crucial to the wall panel's structural integrity and weather resistance. Unless specified otherwise, the fasteners should be evenly spaced across the width of the panel, and to prevent stress concentration, it is important to use the

recommended number of fasteners specified by the manufacturer for each application.

Proper detailing of junctions and openings, incorporating weep holes for effective drainage of any water ingress through panel joints and flashings, as well as appropriate installation practices by specialised professionals, play a vital role in ensuring weatherproofing properties of ISPs. Regular inspections and maintenance are also essential to promptly identify any signs of deterioration and to take necessary corrective measures.

There are a wide range of flashings available, each tailored to specific project requirements. To determine the flashing details appropriate for each installation, it is advisable to discuss the project requirements with the ISP manufacturer and follow their guidelines.

MITIGATION OF THERMAL EXTREMES

ISPs have a wide range of applications, from freezers and cold-rooms, to commercial and residential applications and controlled environments. The resulting temperature differential between internal and external faces can result in thermal bowing. To mitigate this impact, manufacturers often prescribe design and detailing features that accommodate thermal expansion and contraction.

The NCC recognises the impact of darker colours on energy efficiency and imposes restrictions on their usage. In the context of ISP, darker colours not only impact the energy efficiency but also lead to increased thermal deflection and related stresses. Additionally, there is a specific temperature limit for each core material, and it is essential to select a colour compatible with the core material and grade.

DEFINITIONS

- Architectural profiles - generally refer to cladding panels that have wider flat pans and deep standing ribs or recessed ribs.
- 3D mesh - mesh-like mat used to provide a small airgap under cladding to facilitate drainage and drying. Note: 3D mesh assists with oil canning minimization in wide pan profiles.
- Air control membrane - a membrane installed to prevent air transfer between each side of the membrane. Note: Air control membranes are classified as air barriers by AS 4200.1
- Blanket & foil - insulation product installed under cladding (typically roofs) consisting of a layer of bulk insulation adhered to a vapour impermeable reflective membrane.
- Capping - flashing that fully covers the top of a parapet wall, ridge or similar upstand (or “feature”)
- Cavity - a hollow space/void created between two building elements typically the outer metal wall cladding and frame.
- Cavity ventilation - is the process of allowing outside air to flow through a cavity to facilitate drying.
- Cavity wall - a wall that incorporates a drained cavity.
- Closed profile cladding - are those with closed ribs that will not allow easy airflow or drying.
- Concealed fixed (clip fixed) - claddings that are installed and secured using clips. The clips are first installed and secured to the underlying support and then the cladding is engaged to the clips. There are no visible fixings once the cladding is installed.
- Double Skin steel cladding - is more common in commercial building. The system consists of an exterior steel cladding or panel with inner steel cladding typically separated by purlins or battens. Both steel claddings are durable and each steel cladding may provide different weatherproof functions.
- Drainage path - path behind cladding where water drains out to exterior of the building.
- Flashing - a strip or sleeve of impervious material dressed, fitted or built-in to provide a barrier to water movement, or to divert the travel of water, or to cover a joint where water would otherwise penetrate to the interior of a building.

- Impermeable membrane - a pliable building membrane that does not allow the transfer of water vapour across the membrane (Class 1 or 2).
- Insulated sandwich panel (ISP) - an insulated sandwich panel is a factory-made composite building material commonly consisting of two steel outer layers (skins) and a layer of insulation (core) permanently bonded between them.
- Oil canning - visible rippling effect that can occur on the surface of metal panels, particularly flat or lightly profiled metal roofs or metal wall claddings.
- Open profile claddings - are those with open ribs that will allow airflow.
- Permeable (breathable) membrane - a pliable building membrane, including reflective (perforated foil) or non-reflective membrane that does allow the transfer of water vapour across the membrane (Class 3 or 4).
- Pierce fixed (screw fixed) - claddings and flashings that are installed and secured using screws. The screws pierce the cladding and/or structural support. Screw head is generally visible on the surface of the cladding.
- Pliable building membrane - a material that can be folded back on itself without causing structural damage to the product that affects its material properties.
- Reflective foil laminate (RFL) - a building membrane with a reflective surface such as a reflective foil laminate, reflective barrier, foil batt or the like capable of reducing radiant heat flow.
- Reflective space - where a reflective air space is required for energy efficiency cavity shall be 20mm min.
- Self-healing membrane - a pliable building membrane that maintains its properties (water and air control) when penetrated by fasteners.
- Single skin steel cladding - are durable and weatherproof. They are widely used across all building types and are available in a range of colours and finishes and profiles. The metal cladding can be fixed directly to the structure, battens or purlins.
- Thermal Control Membrane - a membrane with a surface emissivity and/or material R-value intended to reduce heat transfer.
- Trickle ventilation - inherent gaps in construction that provide a baseline level of natural ventilation sufficient for drying of wall cavities and roof spaces.
- Water Control Membrane (Sarking) - a membrane classified as a water barrier according to AS 4200.1, intended to collect and discharge any water that may penetrate a building envelope or cladding, excluding damp-proofing and flashing materials. Note: Water control membranes are also commonly referred to as "sarking".
- Vapour barrier - AS 4200.2 (part 2.2)- Where a pliable building membrane is installed as a vapour barrier, class 1 or class 2, it shall be continuously sealed at all discontinuities, end laps, joints and penetrations.
- Vapour control membrane - a pliable building membrane designed to either allow or restrict the transfer of water vapour across the membrane, as classified in Table 1 of AS 4200.1

Vertical Cladding - External Corner - Over Flashing

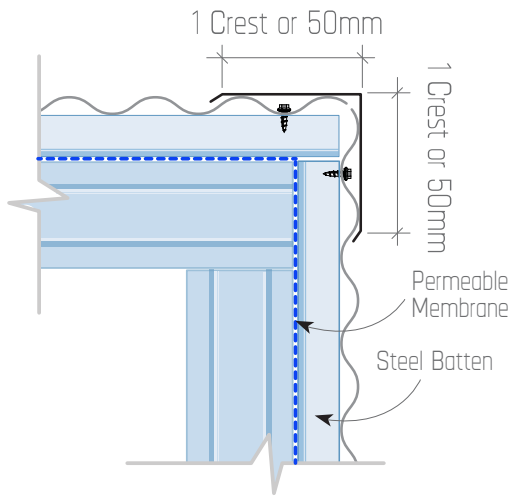

Vertical Cladding - Internal Corner - Over Flashing

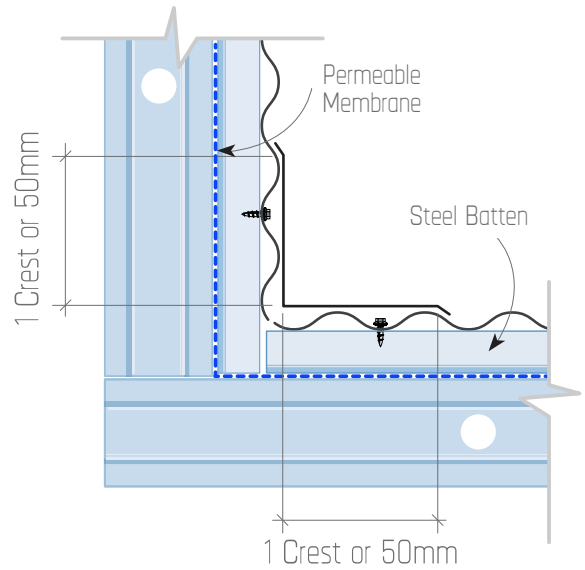

Vertical Cladding - External Corner - Additional Under Flashing

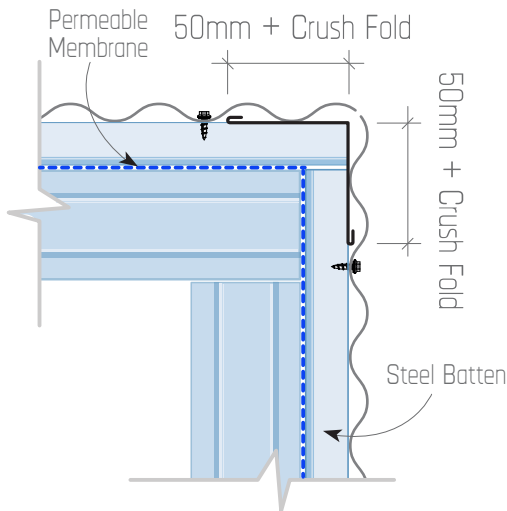

Vertical Cladding - Internal Corner - Additional Under Flashing

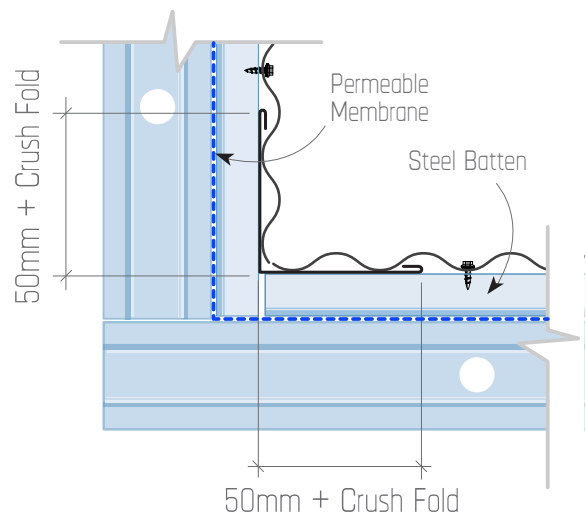

Horizontal Cladding - External Corner - Under Flashing

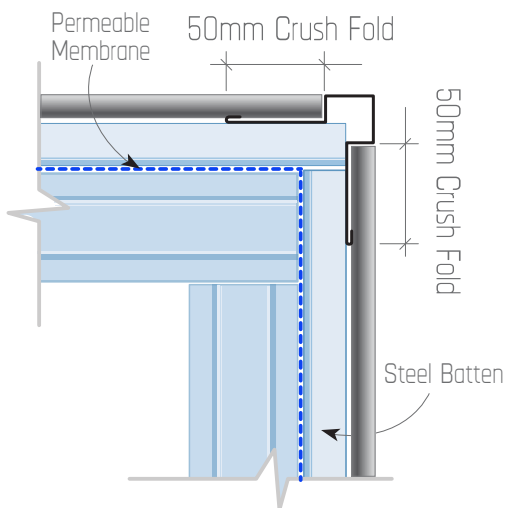

Horizontal Cladding - Internal Corner - Under Flashing

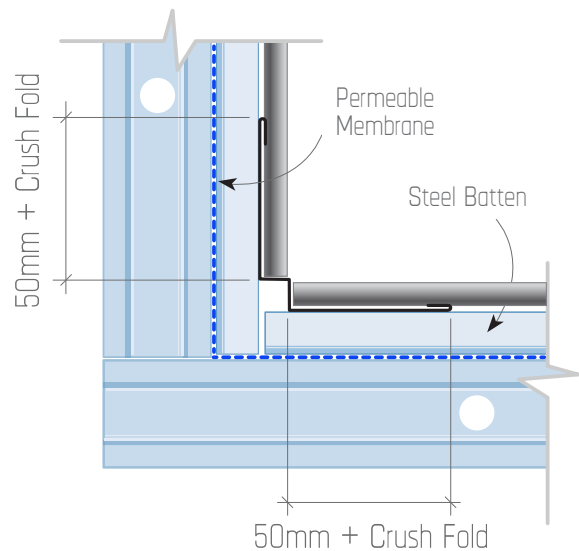

Header/Soffit Eave Flashing

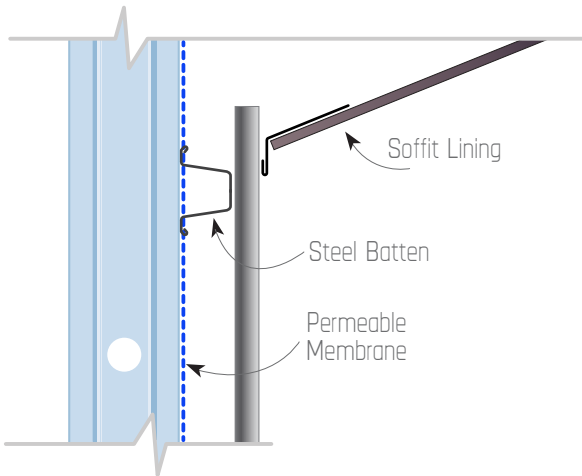

Flashing Window/Door Head

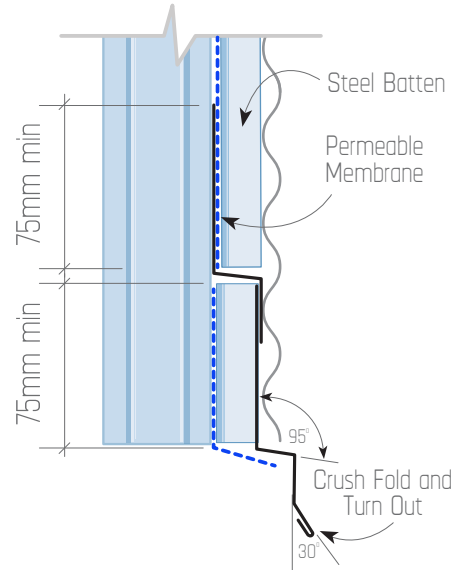

Foot/Toe Mould

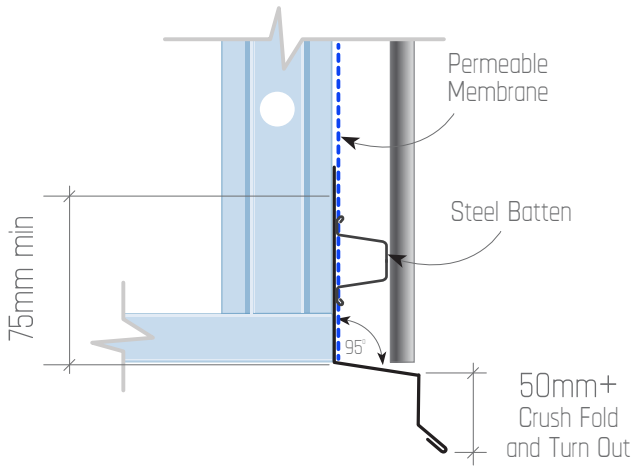

Window/Door Sills

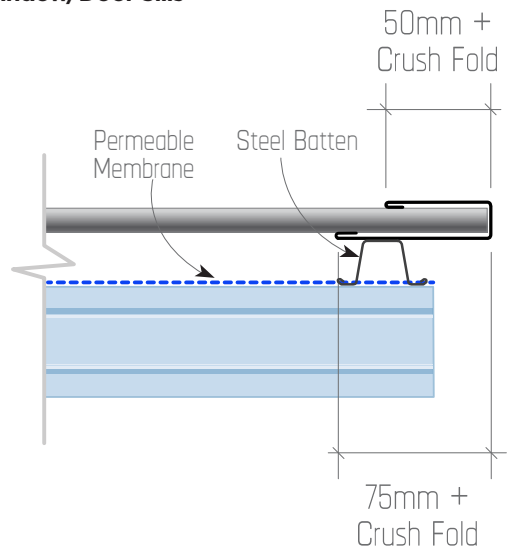

Parapet Flashing

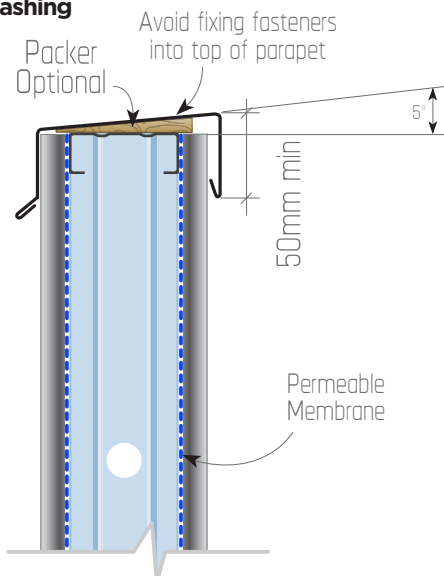

Window/door jamb or Wall junction

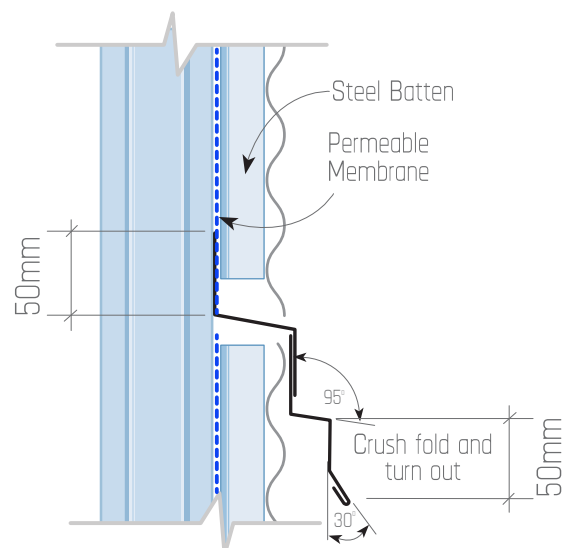

Penetration - Square (Electrical Box) Head

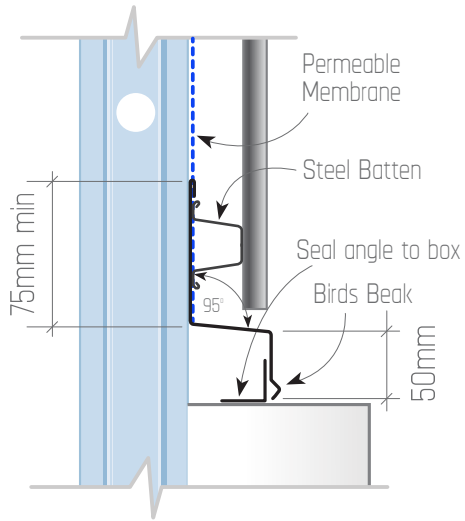

Penetration - Round

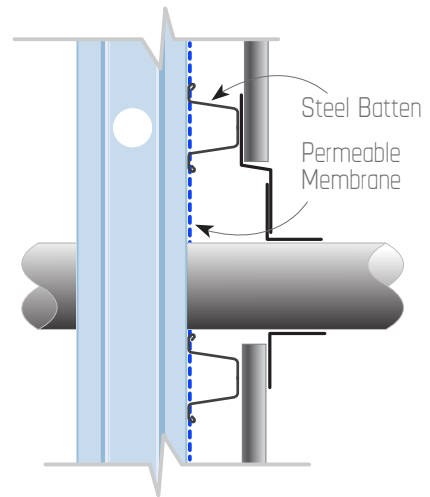

Penetration - Square (Electrical Box) Sill

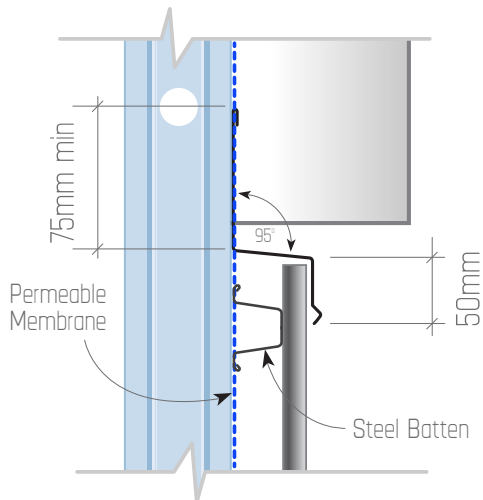

Vertical (Midwall) Control Joints (view from above)

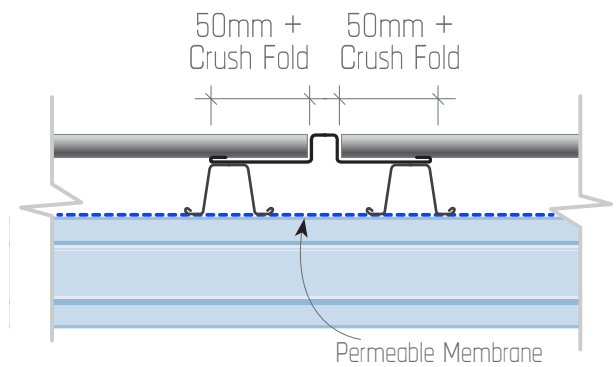

Penetration - Square (Electrical Box) Jamb

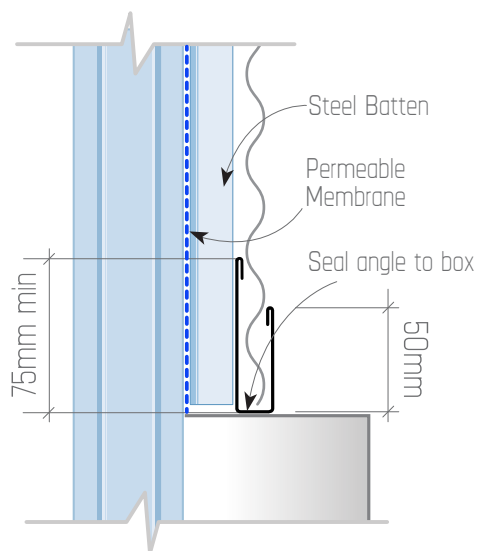

Horizontal Side View (Midwall) Control Joint (side view)

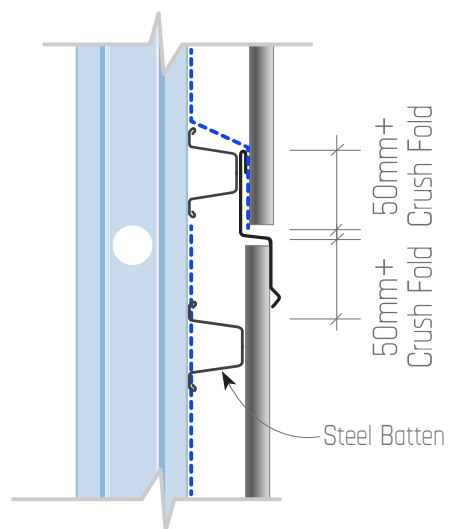



NASH is an Australian industry association representing the interests of fabricators, material suppliers and customers of cold-formed steel structural framing systems for residential and similar construction. NASH develops Standards, Handbooks and Technical Notes for use by the industry and NASH Standards are referenced as Deemed-to-Satisfy solutions in the National Construction Code.

Contact NASH: +61 3 9809 1333
info@nash.asn.au
visit: www.nash.asn.au



AUSTRALIAN STEEL INSTITUTE

The Voice of Australian Steel

The Australian Steel Institute (ASI) is the nation's peak body representing the entire Australian steel supply chain from the manufacturing mills right through to end users in building and construction, heavy engineering and manufacturing.

Disclaimer

The information presented by the ASI, NASH and BlueScope Steel Limited has been sourced and prepared for general information only and does not in any way constitute recommendations or professional advice to any person for any purpose. While every effort has been made and all reasonable care taken to ensure the information contained is accurate and current, this information should not be used or relied upon for any specific application without investigation and verification as to its accuracy, currency, completeness, suitability and applicability by a competent professional person.

The Australian Steel Institute Limited, National Association of Steel Framed Housing Inc. and BlueScope Steel Limited, its officers, employees, consultants and contractors and the authors and editors of the publications contained on this website do not give any warranties or make any representations in relation to the information provided herein and to the extent permitted by law (a) will not be held liable or responsible in any way and (b) expressly disclaim any liability or responsibility for any loss, damage, costs or expenses incurred in connection with this limitation, including loss, damage, costs and expenses incurred as a result of the negligence of the officers, employees, consultants, contractors, authors, editors or publishers.

Contact ASI: +61 2 8748 0180
enquiries@steel.org.au
visit: www.steel.org.au.

