

ENERGY EFFICIENT STEEL FRAMING

**Design principles and compliance pathways
to meet NCC 2022 Energy Efficiency
requirements for residential buildings**

EESF V13 - INDUSTRY 23



AUSTRALIAN STEEL INSTITUTE

CONTENTS

DOCUMENT PURPOSE	2
NCC REQUIREMENTS FOR ENERGY EFFICIENCY IN STEEL FRAMED RESIDENTIAL BUILDINGS	3
COMPLIANCE PATHWAYS	4
OPTIONS/EXAMPLES TO ACHIEVE COMPLIANCE USING THE ELEMENTAL PATHWAY	5 - 9
SUMMARY	10
NASH, ASI & CONTACTS	11

DOCUMENT PURPOSE

The purpose of this document is to provide guidance for designers and builders including:

- An overview of new NCC 2022 Energy Efficiency provisions that impact framed residential buildings and pathways for compliance available to designers
- An explanation of the new requirements for thermal bridging mitigation
- Examples of some common easy to install construction solutions that meet requirements when following the Dts Elemental pathway
- Where to go for further information

Energy Efficiency is a complex area of focus in NCC 2022 for residential buildings (Volume Two for Class 1 houses and Volume One for Class 2 apartments). Designers and construction professionals should refer to the National Association of Steel-Framed Housing Inc. (NASH) website (nash.asn.au) for guidance publications and presentations to enhance understanding of new requirements, tables to assist with solutions, and straightforward information on practical, cost-effective construction methods.



AUSTRALIAN STEEL INSTITUTE

NCC REQUIREMENTS FOR ENERGY EFFICIENCY IN STEEL FRAMED RESIDENTIAL BUILDINGS

Federal and State Governments have committed to reducing the carbon footprint of the built environment as part of efforts to address climate change.

With NCC2022 more stringent levels of energy efficiency in residential buildings have been introduced, in recognition of the high proportion of energy and carbon emissions that come from this sector as well as the impact thermal performance can have on improving occupant health and amenity.

From a thermal performance perspective, when using NatHERS software as an assessment tool, homes will be required to move from 6-star to 7-star energy rating. For Class 2 apartment

buildings, an average of 7 stars needs to be achieved with not less than 6 stars for any one unit. A new “Whole of Home” approach to energy usage of the building has also been introduced which takes account of the energy consumption of fixed appliances (e.g. heating, cooling, hot water, cooking, lighting, pool & spa equipment).

Energy efficiency performance requirements apply to all new houses and apartments, irrespective of construction materials used.

The impact on construction of steel framed houses will in most cases be nominal, and in some cases may require less insulation than for a timber framed house.

THERMAL BRIDGING MEASURES (NEW FOR NCC 2022)

When a building element contains framing members with lower thermal resistance than surrounding materials, more heat is conducted through these members. This effect can reduce the thermal performance of the insulation layer and is commonly referred to as “conductive thermal bridging”. Commonly used frames of timber and steel both exhibit conductive thermal bridging, the effect being more pronounced with steel members.

NCC 2019 introduced a requirement that conductive thermal bridging be taken into account in determining the thermal properties of framed building elements in commercial buildings. NCC 2022 introduces this requirement for houses and apartments.

The task of estimating thermal resistance and allowing for thermal bridging is the responsibility of building designers and suppliers. The requirements and methods vary for houses and apartments and for timber and steel construction. Just how much thermal bridging occurs in a particular form of construction depends on a number of factors. However, in most common situations the effect can be reduced or “mitigated”

with very small and simple adjustments to the specifications. NASH offers a range of industry guidance to assist designers to meet the new requirements for steel framed construction.



COMPLIANCE PATHWAYS

How the thermal resistance of external building elements – roofs, ceilings, walls and floors – is taken into account when calculating overall thermal performance of a home depends on the Compliance Pathway chosen by the building designer.

The NCC energy efficiency provisions are set out in Volume One Part J1 for apartments and in Volume Two Part H6 for houses. They cover the following items:

- Thermal performance based on heating and cooling load limits (Volume One Part J1P2, Volume Two Part H6P1) and
- Energy usage of domestic services (Volume One Part J1P3, Volume Two Part H6P2).

Requirements can be met by providing a Performance Solution that meets the relevant performance requirements (eg using the Verification Method set out in Part J1V5 or H6V2) OR by a Deemed-to-Satisfy (DtS) solution.

Most commonly designers will use DtS solutions as set out in Part J2D2 for apartments and Parts H6D1 and H6D2 for houses. DtS solutions fall into two categories: House Energy Rating Software (DtS NatHERS) or element-by-element design (DtS Elemental).

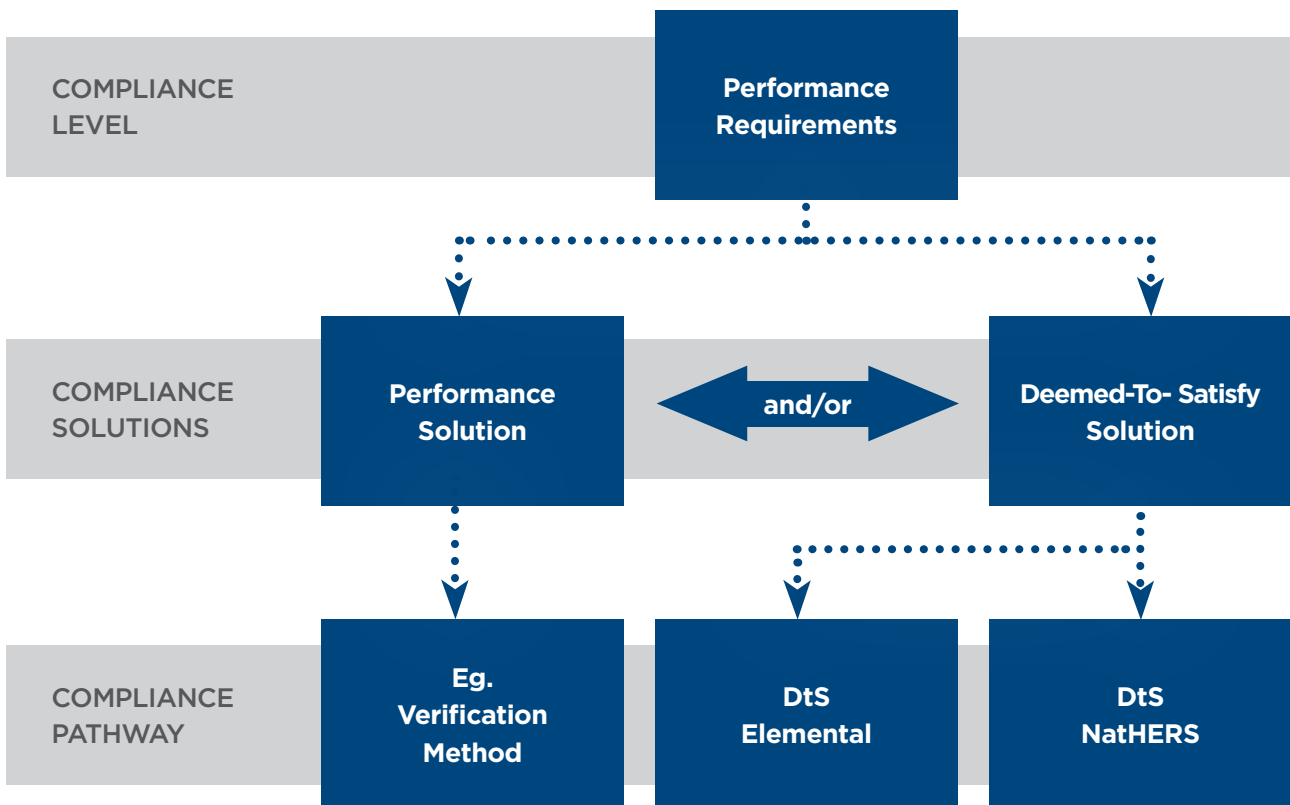

Which ever compliance path is chosen by the designer, the result is a thermal design specification to be followed in construction. This isn't new – there are just some small changes in the quantity or configuration of some insulation

materials when constructing a steel framed building. These are explained in this document and in other helpful trade guides.

Compliance via DtS NatHERS Pathway

NatHERS energy rating software is the most common pathway used by industry to demonstrate NCC compliance. NatHERS solutions use accredited software containing thermal conductivity data for common building materials and algorithms to estimate thermal bridging when steel-framed building elements are being modelled. Trade-offs are permitted by increasing or decreasing the thermal performance of each element (roofs, walls, floors, glazing) during the assessment process. In NSW, this option may be used to satisfy the thermal performance standards of BASIX.

For NCC 2022, there are many changes and all software has been updated. Care needs to be taken that energy assessment is done by trained and experienced energy assessors using up-to-

date versions of accredited software, regardless of materials used. The energy rating impacts of thermal bridging in steel framing are not large but are highly dependent on modelling inputs and approaches. Modelling guidance provided in the NatHERS Assessor Handbook and the Thermal Bridging of Steel Framing in NatHERS Software guidance document prepared by NASH and BlueScope should be followed for all assessments.

Following correct software procedures, 7 star ratings for both timber and steel framed construction may be achieved with similar levels of insulation and appropriate membranes.

Compliance via DtS Elemental Pathway

The intention of the NCC is that building thermal performance outcomes from following the Elemental pathway should align with the NatHERS pathway regardless of construction materials. Consequently, while the Elemental pathway is not as widely used by designers, the examples that are discussed in this document are relevant to understanding the relative changes required for steel framed construction vs timber framed construction. These changes should be broadly similar when following the NatHERS pathway. This may not be obvious to designers and builders due to the NatHERS solutions allowing more trade-offs than Elemental solutions. This can give rise to misconceptions about the effect the framing material has on achieving a 7 star outcome.

As we will explain by looking at examples following the Elemental pathway, solutions can easily be achieved for steel framed construction through small amounts of insulation and/or reflective airspaces. Steel framing can actually require less insulation than timber in some cases, depending on style of construction eg wider truss and rafter spacing.

NASH Technical Note NTN-006 has been developed to assist designers to develop cost-effective energy efficiency solutions for steel framed construction when following the Elemental pathway, providing easy to follow tables and guidance.

OPTIONS/EXAMPLES TO ACHIEVE COMPLIANCE USING THE ELEMENTAL PATHWAY

For Class 1 houses and for the roofs of Class 2 apartments, the ABCB Housing Provisions Standard provides a set of tables for each Climate Zone containing acceptable combinations of roof type, roof colour, eave width, wall material, wall height, etc. The tables use timber framed construction as the baseline for insulation requirements for each building element. Separate lookup tables then provide options to mitigate thermal bridging where steel framing is used, such as increased insulation, addition of a reflective airspace or calculating an R-value against a target. For the walls of Class 2 apartments, the designer needs to apply specific rules for the opaque portions of wall related to floor or glazing area. This is a specialised area for the designer.

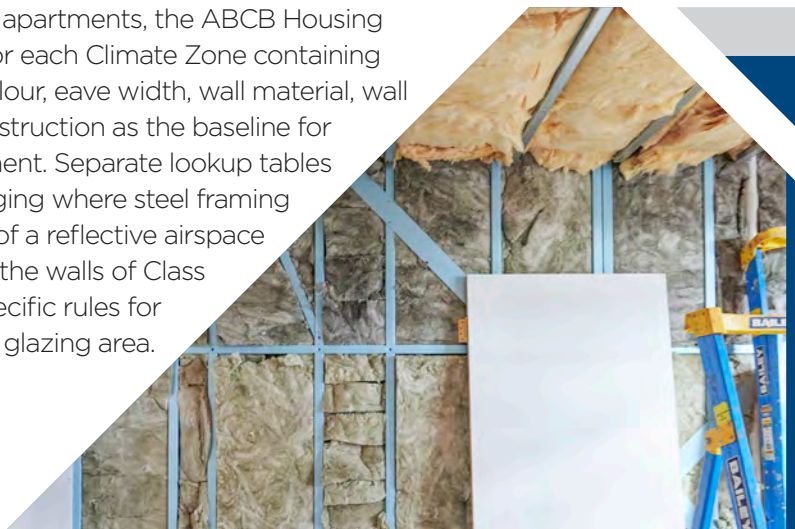

CEILING SOLUTION

An example of how the ceiling insulation timber-framed solution is determined for houses in Climate Zone 6 is shown in Table 13.2.3g

Table 13.2.3g: Pitched roof with horizontal ceiling- minimum R-Value for ceiling insulation: Climate Zone 6

Roof Ventilation	Reflective Insulation under-roof	Under-roof insulation R-Value	0.23≤SA≤0.64	0.64<SA≤0.96
Vented	Yes	<1.0	4.0	3.5
		≥1.0	3.5	
	No	<1.0	4.0	
		≥1.0	3.5	
Standard	Yes	<1.0	3.5	
		≥1.0	3.0	
	No	<1.0	4.0	
		≥1.0	3.5	

Table Notes:

1. SA=Solar Absorbance
2. A roof is considered 'vented' if it:
 - (a) Has one wind-driven roof ventilator per 50m² of ceiling area, with gable, eave or ridge vents; or
 - (b) Has one powered roof ventilator per 200m² of ceiling area, with gable, eave or ridge vents; or
 - (c) Is ventilated to outdoor air through evenly distributed openings with Table 10.8.3; or
 - (d) Is a tiled roof without sarking-type material at roof level.
3. If a roof is not 'vented', it is a 'standard' roof.
4. In climate zones 6, 7 and 8, roof ventilation must comply with 10.8.3.
5. The R-Value of reflective insulation is not to be included in the R-Value of any under-roof ceiling insulation.
6. R-Values listed are for the labelled, declared R-Value of insulation.

For the steel solution, the designer needs to adjust the insulation as specified in the following extract from the Housing Provisions:

The thermal bridging in a metal-framed roof must be addressed as follows:

- (a) For pitched roof with a horizontal ceiling:
 - (i) Achieving the Total R-Value in Table 13.2.3s, calculated using a method that accounts for the effects of thermal bridging; or
 - (ii) Increasing the R-Value of the insulation between the ceiling frames by R0.5 more than the R-Value derived from (i); or
 - (iii) Adding a continuous ceiling insulation layer with a minimum R-Value of R0.13 above or below the ceiling joists or the bottom chords of the trusses; or
 - (iv) Achieving the required ceiling R-Value derived from (i) by stacking two layers of insulation immediately on top of each other, such that the top layer is orientated to cover the ceiling joists or bottom chords of the trusses and has an R-Value of at least R0.5; or

In most cases, the first option provides the most cost-effective solution. A minimum ceiling Total R-value must be achieved based on the timber insulation solution, as shown in the table 13.2.3s.

Table 13.2.3s: Metal-framed pitched roof with horizontal ceiling - minimum Total R-Value of ceiling to account for thermal bridging.

Minimum ceiling insulation R-Value from Tables 13.23a to 13.2.3i as applicable	1.5	2.0	2.5	3.0	3.5	4.0	4.5	5.0	5.5	6.0
Minimum ceiling Total R-Value	1.38	1.74	2.09	2.43	2.63	2.95	3.27	3.59	3.91	4.23

Table Notes:

1. The total R-Value calculated only includes the ceiling frame, insulation and ceiling lining. It is not to include internal air films, roof space or roof lining.
2. Minimum ceiling total R-Value are in-situ values. They account for compression of insulation.

NASH has developed Technical Note NTN006 “NCC 2022 Elemental Energy Efficiency Solutions - Class 1 Buildings” to guide designers to compliant, practical, cost-effective solutions for all external building elements. Examples for trussed roof ceilings and raftered roofs are shown below, together with an overview of expected construction solutions.

TRUSSED ROOF SOLUTION

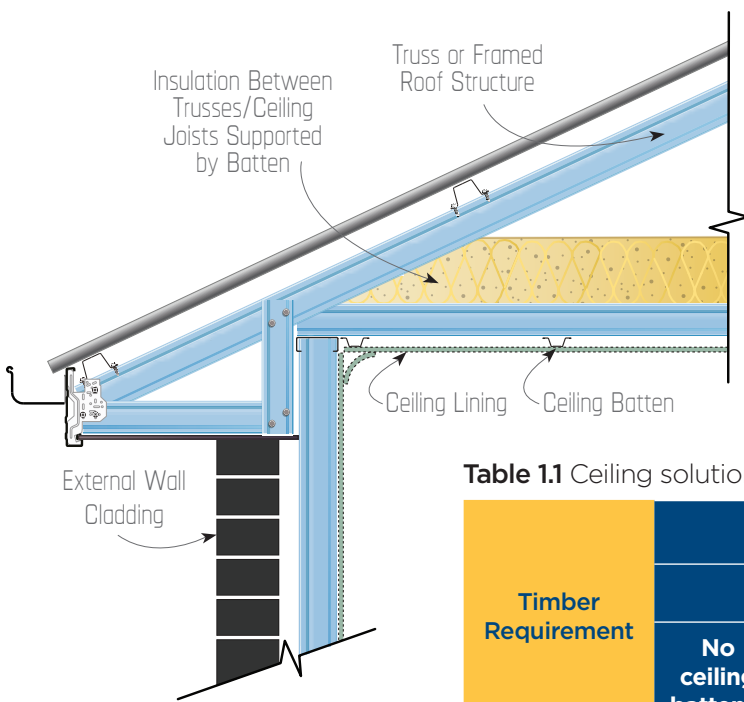

Pitched Trussed Roof, Horizontal Ceiling

EXPECTED CONSTRUCTION SOLUTIONS

- In most climate zones, timber solution requires **R2.5 to R4.0**
- Steel trusses at ≤ 600 : **add R0.5**
- Steel trussed at wider spacings: **Same insulation as timber or less**

Table 1.1 Ceiling solutions with large air space above ceiling.

Timber Requirement	Steel Insulation				
	Truss spacings (mm)				
	No ceiling battens*	Includes ceiling battens			
Insulation value	≤ 600	600	900	1200	1500
R2.5	R3.0	R3.0	R2.5	R2.5	R2.5
R3.0	R3.5	R3.5	R3.0	R3.0	R3.0
R3.5	R4.0	R3.5	R3.5	R3.0	R3.0
R4.0	R4.5	R4.0	R4.0	R3.5	R3.5
R4.5	R5.0	R4.5	R4.0	R4.0	R4.0
R5.0	R5.5	R5.0	R4.5	R4.5	R4.5

*ABC Housing Provisions Standard Clause 13.2.3(3)(a)(ii)

RAFTERED ROOF SOLUTION

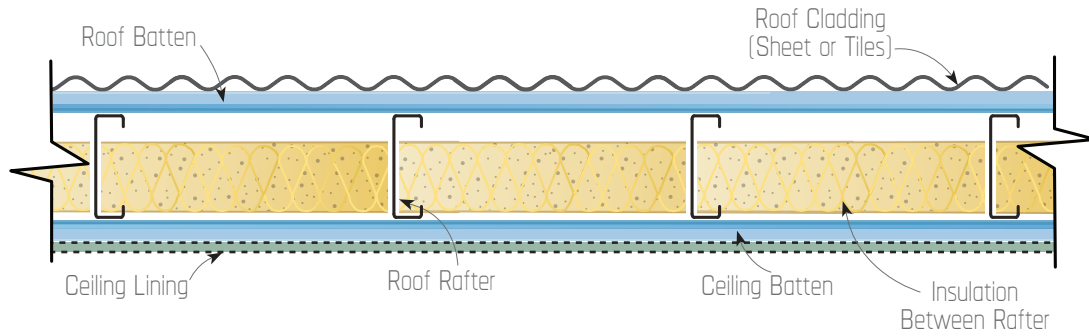

Raftered Roof, Sloping Ceiling

Table 1.2 Sloping roofs with minimum air space above primary insulation layer

Timber Requirement		Steel insulation			
		Truss spacing (mm)			
Insulation value	Reflective membrane ¹	600	900	1200	1500
R2.5	Yes	R3.0	R2.5	R2.5	R2.0
	No	R4.0	R3.5	R3.0	R3.0
R3.0	Yes	R4.0	R3.0	R3.0	R2.5
	No	x	R4.0	R3.5	R3.5
R3.5	Yes	R4.5	R3.5	R3.0	R3.0
	No	x	R4.5	R4.0	R4.0
R4.0	Yes	x	R4.0	R3.5	R3.5
	No	x	x	R5.0	R4.5
R4.5	Yes	x	R5.0	R4.5	R4.0
	No	x	x	x	R5.0
R5.0	Yes	x	x	R5.0	R4.5
	No	x	x	x	x

1. x = No DTS Elemental Solution
2. Reflective membrane with downward facing emittance ≤ 0.05 and upward facing emittance ≤ 0.10
3. All solutions include ceiling battens
4. Specific membrane properties may be required for waterproofing or condensation control.

EXPECTED CONSTRUCTION SOLUTIONS

- In most climate zones, timber solution requires **R2.5 to R4.0**
- Steel rafters at 600: **Up to R1.5 more than timber**
- Steel rafters at 900 - 1500:
 - Without reflective membrane: **Up to R1.0 (typically R0.5) more than timber**
 - With reflective membrane: **Typically same insulation as timber.**
- Steel rafters at 600 - 1500 with roofing blanket: **Same or up to R0.5 less than timber.**

BRICK VENEER WALL SOLUTION

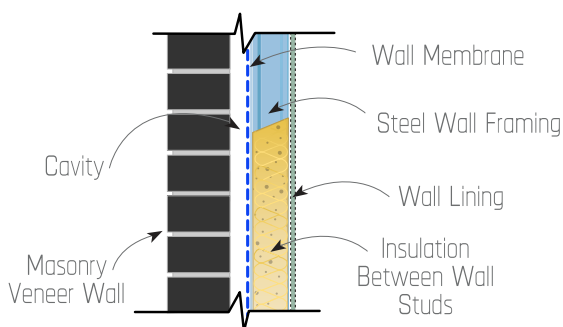

EXPECTED CONSTRUCTION SOLUTIONS

- In most climate zones, timber solution requires **R1.5 to R3.5**
- With reflective membrane, **use same insulation as timber**
- Low emissivity membranes **require less insulation.**

CLAD WALL SOLUTION

EXPECTED CONSTRUCTION SOLUTIONS

- In most climate zones, timber solution requires **R1.8 to R3.8**
- Steel framing with battened reflective airspace requires **same or less wall insulation than timber.** (Also, due to wall depth, some 7-star solutions may be possible in steel but not timber)
- Continuous insulation options require **same insulation as timber.**
- For cladding directly fixed to studs, thermal breaks continue to be required as per NCC 2019.

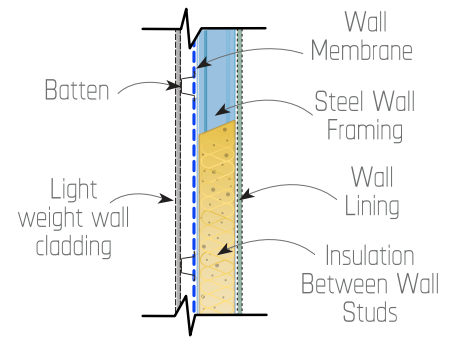

Apartment External Walls (Facades)

External walls of Class 2 apartments are treated differently to houses. To determine the required R-Value of the opaque wall portion, the designer needs to consider one of two area-based methods:

1. Ratio of opaque wall area to floor area
2. Ratio of opaque wall area to total wall-glazing area.

These methods give different results depending on building geometry. Designers would typically use calculation tools and tables provided by industry to determine suitable compliant design solutions. Note that the requirement to consider the effects of thermal bridging for apartment external walls applies equally to timber and steel framed construction when using the DtS Elemental pathway.

THERMAL BREAKS (UNCHANGED FROM NCC 2019)

With NCC 2022, the requirement for thermal breaks for steel framed buildings remains unchanged from NCC 2019 ie a thermal break with a minimum R value of 0.2 is required for roofs and walls where the external lightweight cladding and internal lining are fixed to the same member, eg wall stud or roof rafter. For roofs, lightweight cladding refers only to metal roof sheeting and for walls, includes weatherboards, fibre-cement and metal wall cladding.

Thermal breaks are not required when either the lightweight cladding or the lining is fixed to a secondary member (batten). Note that Insulated Sandwich Panels do not require a thermal break.

An easy to install construction measure to address thermal bridging in steel framed external walls would be to install a reflective membrane with a 20mm airspace.

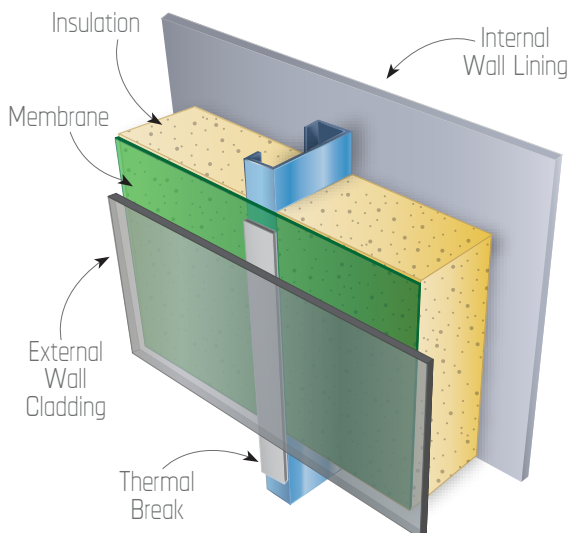

Thermal Break Needed

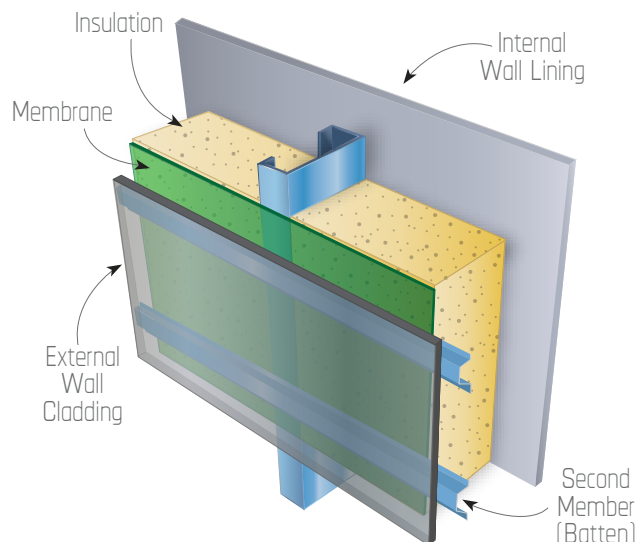

Thermal Break NOT Needed

SUMMARY

The increased stringency in residential energy efficiency requirements in NCC2022 will mean that higher levels of insulation are likely to be required in some or all parts of the building fabric, for all forms of construction. The requirements for thermal breaks for steel-framed buildings will remain unchanged from NCC 2019. The new requirement for steel-framed buildings to employ thermal bridging mitigation techniques can be met with simple, cost-effective, easy to install construction solutions.

NASH Technical Note NTN006 “NCC 2022 Elemental Energy Efficiency Solutions - Class 1 Buildings” and other tools are available on the NASH website for designers seeking further guidance.



NASH is an Australian industry association representing the interests of fabricators, material suppliers and customers of cold-formed steel structural framing systems for residential and similar construction. NASH develops Standards, Handbooks and Technical Notes for use by the industry and NASH Standards are referenced as Deemed-to-Satisfy solutions in the National Construction Code.

Contact NASH: +61 3 9809 1333
info@nash.asn.au
visit: www.nash.asn.au



AUSTRALIAN STEEL INSTITUTE

The Voice of Australian Steel

The Australian Steel Institute (ASI) is the nation's peak body representing the entire Australian steel supply chain from the manufacturing mills right through to end users in building and construction, heavy engineering and manufacturing.

Disclaimer

The information presented by the ASI, NASH and BlueScope Steel Limited has been sourced and prepared for general information only and does not in any way constitute recommendations or professional advice to any person for any purpose. While every effort has been made and all reasonable care taken to ensure the information contained is accurate and current, this information should not be used or relied upon for any specific application without investigation and verification as to its accuracy, currency, completeness, suitability and applicability by a competent professional person.

The Australian Steel Institute Limited, National Association of Steel Framed Housing Inc. and BlueScope Steel Limited, its officers, employees, consultants and contractors and the authors and editors of the publications contained on this website do not give any warranties or make any representations in relation to the information provided herein and to the extent permitted by law (a) will not be held liable or responsible in any way and (b) expressly disclaim any liability or responsibility for any loss, damage, costs or expenses incurred in connection with this limitation, including loss, damage, costs and expenses incurred as a result of the negligence of the officers, employees, consultants, contractors, authors, editors or publishers.

Contact ASI: +61 2 8748 0180
enquiries@steel.org.au
visit: www.steel.org.au.

